



D E S I G N E D T O L E A D

BWC Series

**High Efficiency Gas-Fired Hot Water
Direct Vent Condensing Boilers**

INSTALLATION INSTRUCTIONS

These instructions must be affixed on or adjacent to the boiler.



Models:

- **BWC150**
- **BWC225**

WARNING: Improper installation, adjustment, alteration, service or maintenance can cause property damage, injury, or loss of life. For assistance or additional information, consult a qualified installer, service agency or the gas supplier. This boiler requires a special venting system. Read these instructions carefully before installing.



Manufacturer of Hydronic Heating Products
P.O. Box 14818 3633 I. Street
Philadelphia, PA 19134
www.crownboiler.com

Table of Contents

I.	Product Description	2
II.	Specifications	2
III.	Before Installing	3
IV.	Locating The Boiler	3
V.	Air For Ventilation	5
VI.	Venting	7
	Vent System Design	7
	Removing An Existing Boiler From Common Chimney	14
	Vent/Intake System Assembly	14
VII.	Gas Piping	23
VIII.	System Piping	24
	General System Piping Precautions	24
	System Design	24
	Standard Piping Installation Requirements	31
	Piping For Special Situations	32
IX.	Wiring	34
X.	Start-up and Checkout	38
XI.	Operation	44
XII.	Service and Maintenance	49
XIII.	Troubleshooting	51
XIV.	Parts	55
	Appendix A Special Requirements For Side-Wall Vented Appliances In The Commonwealth of Massachusetts	69

I Product Description

The BWC is an aluminum gas fired condensing boiler designed for use in forced hot water heating systems requiring supply water temperatures of 180°F or less. This boiler may be vented vertically or horizontally with combustion air supplied from outdoors. This boiler is not designed for use in gravity hot water systems or systems containing significant amounts of dissolved oxygen.

II Specifications

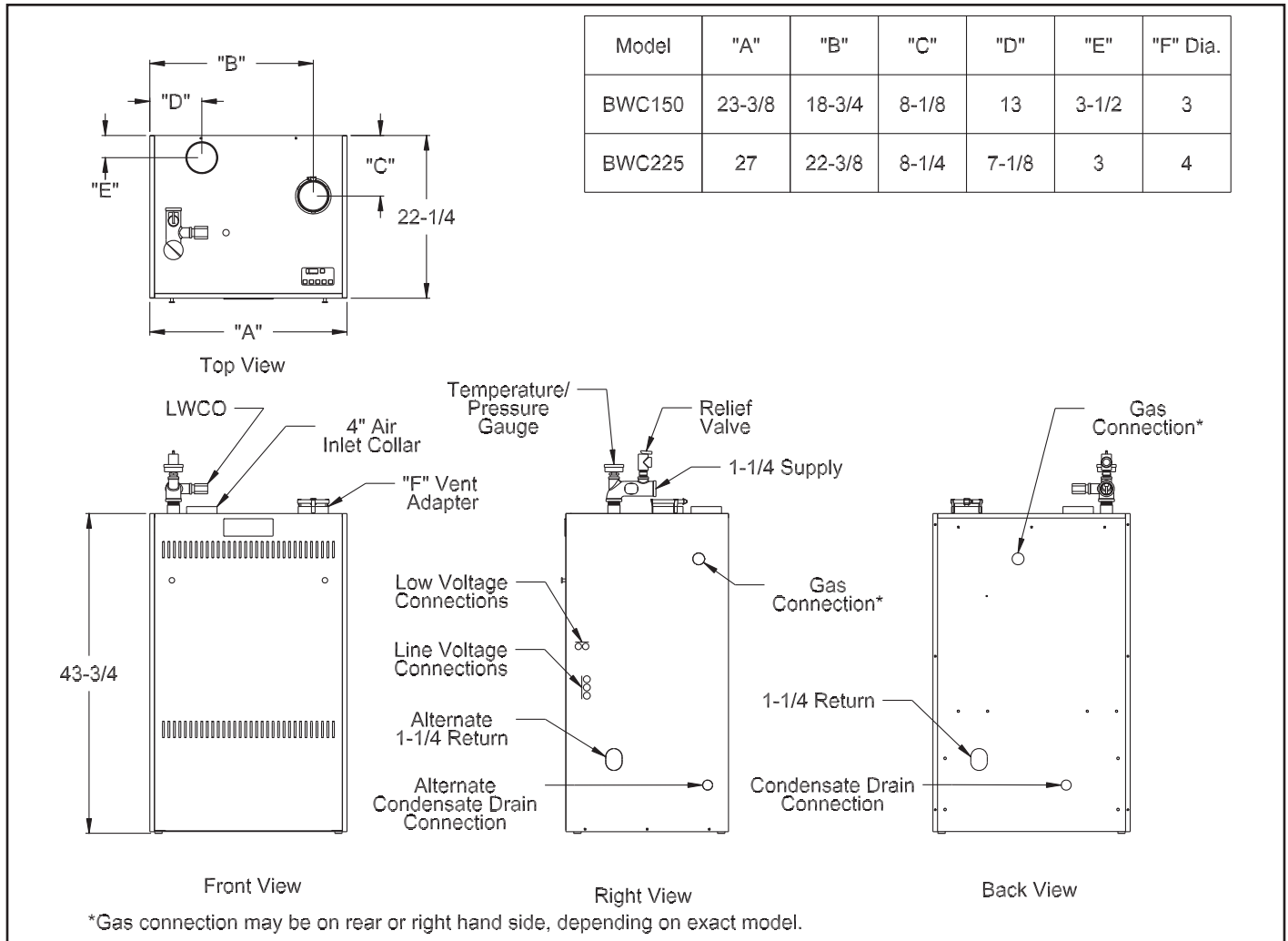

Figure 2.1: General Configuration

Table 2.2: Specifications

MODEL*	NO. OF SECTIONS	MAXIMUM INPUT (BTU/hr)	MINIMUM INPUT (BTU/hr)	D.O.E. HEATING CAPACITY (BTU/hr)	AHRI NET RATING (BTU/hr)	VENT COLLAR DIAMETERS (IN.)	
						INLET	EXHAUST
BWC150	3	150,000	50,000	133,000	117,000	4	3
BWC225	4	225,000	75,000	202,000	176,000	4	4

* MODELS SHOWN ARE FOR NATURAL GAS. ADD "LP" SUFFIX TO MODEL NUMBER SHOWN FOR PROPANE MODEL NUMBER (ie BWC225LP). PERFORMANCE RATINGS ARE THE SAME FOR BOTH FUELS.

III Before Installing

- 1) Safe, reliable operation of this boiler depends upon installation by a professional heating contractor in strict accordance with this manual and the authority having jurisdiction.
 - In the absence of an authority having jurisdiction, installation must be in accordance with this manual and the *National Fuel Gas Code*, ANSI Z223.1. In Canada, installation must be in accordance with the B149.1 Installation Code
 - Where required by the authority having jurisdiction, this installation must conform to the *Standard for Controls and Safety Devices for Automatically Fired Boilers* (ANSI/ASME CSD-1).
- 2) BWC boilers utilize aluminum heat exchangers constructed, tested, and stamped in accordance with ASME Boiler and Pressure Vessel Code Case 2382-2. Some jurisdictions which require ASME boiler construction do not recognize this Code Case and may not approve the installation of an aluminum boiler. Consult the authority having jurisdiction before installing this boiler.
- 3) Read Section VI to verify that the maximum combustion air and exhaust pipe lengths will not be exceeded in the planned installation. Also verify that the vent terminal can be located in accordance with Section VII.
- 4) Make sure that the boiler is correctly sized:
 - For heating systems employing convection radiation (baseboard or radiators), use an industry accepted sizing method such as the *I=B=R* Guide RHH published by the Air-Conditioning, Heating and Refrigeration Institute (AHRI).
 - For new radiant heating systems, refer to the radiant tubing manufacturer's boiler sizing guidelines.
 - For systems including a Crown Mega-Stor indirect water heater, size the boiler to have either the DOE Heating Capacity required for the Mega-Stor or the net rating required for the heating system, whichever results in the larger boiler.
 - For systems that incorporate other indirect water heaters, refer to the indirect water heater manufacturer's instructions for boiler output requirements.
- 5) Make sure that the boiler received is configured for the correct gas (natural or LP).
- 6) Make sure that the boiler is configured for use at the altitude at which it is to be installed.

NOTICE

This product must be installed by a licensed plumber or gas fitter when installed within the Commonwealth of Massachusetts. See Appendix A for additional important information about installing this product within the Commonwealth of Massachusetts.

IV Locating the Boiler

- 1) Observe the minimum clearances shown in Figure 4.1. These clearances apply to both combustible and non-combustible materials. Observe the minimum clearances to combustibles for vent pipe shown in Table 4.2.
- 2) Note the recommended service clearances in Figure 4.1. The recommended service clearances may be reduced to the minimum combustible clearances with the understanding that servicing the boiler will become increasingly difficult as the clearance is reduced.
- 3) Boiler may be installed on non-carpeted combustible surface.
- 4) The relief valve must be installed in the factory specified location.
- 5) The boiler should be located so as to minimize the length of the vent system.
- 6) The combustion air piping must terminate where outdoor air is available for combustion and away from areas that will contaminate combustion air. Avoid areas near chemical products containing chlorine, chloride based salts, chloro/fluorocarbons, paint removers, cleaning solvents and detergents.

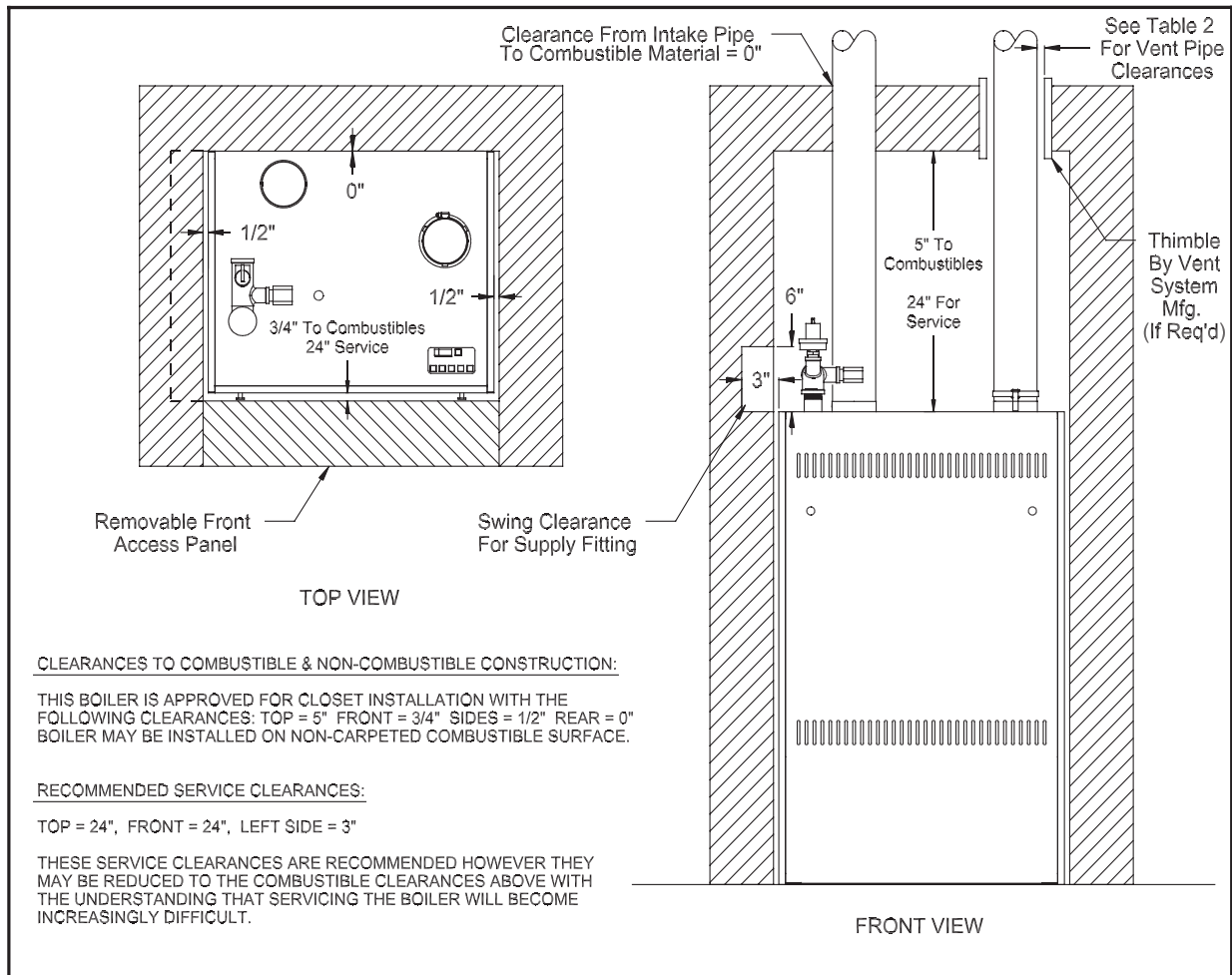

Figure 4.1: Clearances To Combustible Or Non-combustible Material

Table 4.2: Clearances From Vent Piping To Combustible Construction

TYPE OF VENT PIPE	PIPE DIRECTION	ENCLOSURE	MINIMUM CLEARANCE TO COMBUSTIBLE MATERIAL
HEAT FAB SAF-T VENT PROTECH FASNSEAL Z-FLEX Z-VENT III METAL-FAB CORR-GUARD	VERTICAL OR HORIZONTAL	AT LEAST ONE SIDE OPEN, COMBUSTIBLE MATERIAL ON A MAXIMUM OF THREE SIDES	1"
HEAT FAB SAF-T VENT PROTECH FASNSEAL Z-FLEX Z-VENT III METAL-FAB CORR-GUARD	HORIZONTAL OR VERTICAL WITH OFFSETS	ENCLOSED ON ALL FOUR SIDES	2-1/2"
HEAT FAB SAF-T VENT PROTECH FASNSEAL Z-FLEX Z-VENT III METAL-FAB CORR/GUARD	VERTICAL WITH NO OFFSETS	ENCLOSED ON ALL FOUR SIDES	2-1/2"

WARNING

OUTDOOR COMBUSTION AIR MUST BE PIPED TO THE AIR INTAKE. NEVER PIPE COMBUSTION AIR FROM AREAS CONTAINING CONTAMINATES SUCH AS SWIMMING POOLS AND LAUNDRY ROOM EXHAUST VENTS. CONTAMINATED COMBUSTION AIR WILL DAMAGE THE BOILER AND MAY CAUSE PROPERTY DAMAGE, PERSONAL INJURY OR LOSS OF LIFE.

V Air for Ventilation

Air for combustion must always be obtained directly from outdoors, however sufficient air for ventilation must still be provided in the boiler room. Air for ventilation is required to keep various boiler components from overheating and is always obtained from indoors. To ensure an adequate ventilation air supply, perform the following steps:

Step 1: Determine whether the boiler is to be installed in a confined space - A confined space is defined by the *National Fuel Gas Code* as having a volume less than 50 cubic feet per 1000 BTU/hr input of all appliances installed in that space. To determine whether the boiler room is a confined space:

- 1) Total the input of all appliances in the boiler room in thousands of BTU/hr. Round the result to the next highest 1000 BTU/hr.
- 2) Find the volume of the room in cubic feet. The volume of the room in cubic feet is:

Length (ft) x width (ft) x ceiling height (ft)

In calculating the volume of the boiler room, consider the volume of adjoining spaces only if no doors are installed between them. If doors are installed between the boiler room and an adjoining space, do not consider the volume of the adjoining space, even if the door is normally left open.

- 3) Divide the volume of the boiler room by the input in thousands of BTU/hr. If the result is less than 50, the boiler room is a confined space.

Example:

A BWC225 and a water heater are to be installed in a room measuring 6ft – 3 in x 7ft with an 8 ft ceiling. The water heater has an input of 30000 BTU/hr:

Total input in thousands of BTU/hr = (225000 BTU/hr + 30000 BTU/hr) / 1000 = 255 MBTU/hr

Volume of room = 6.25 ft x 7 ft x 8 ft = 350 ft³

350/255 = 1.37. Since 1.37 is less than 50, the boiler room is a confined space.

Step 2a: If the boiler is to be placed in a confined space, provide two openings into the boiler room, one near the floor and one near the ceiling. The top edge of the upper opening must be within 12” of the ceiling and the bottom edge of the lower opening must be within 12” of the floor (Fig 5.1). The minimum opening dimension is 3 inches.

- If the BWC boiler is the only gas-burning appliance in the boiler room, these openings must each have a minimum free area of 100 square inches.
- If other gas-burning appliances are in the boiler room, size the openings in accordance with the appliance manufacturer’s instructions or the *National Fuel Gas Code*. Minimum opening free area is 100 square inches even if opening requirements for other appliances are less.

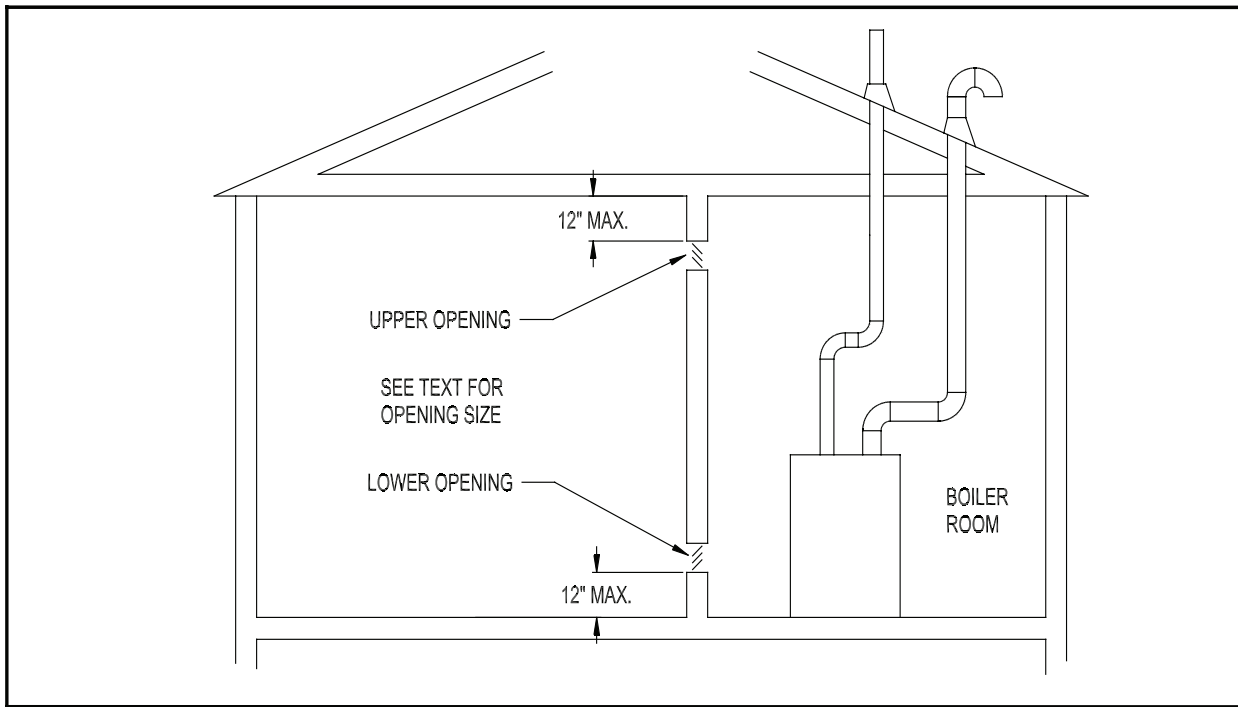

Figure 5.1: Boiler Installed In A Confined Space, Ventilation Air From Inside

- If the total volume of both the boiler room and the room to which the openings connect is less than 50 cubic feet per 1000 BTU/hr of total appliance input, install a pair of identical openings into a third room. Connect additional rooms with openings until the total volume of all rooms is at least 50 cubic feet per 1000 BTU/hr of input.
- The “free area” of an opening takes into account the blocking effect of mesh, grills, and louvers. Where screens are used, they must be no finer than 1/4” (4 x 4) mesh.

Step 2b: If the boiler is to be placed in an unconfined space the natural infiltration into the boiler room will provide adequate air for ventilation without additional openings into boiler room.

VI Venting

WARNING

Failure to vent this boiler in accordance with these instructions could result in unreliable boiler operation, severe damage to the boiler or property, or unsafe operation:

- * Use only vent systems and materials explicitly permitted by Crown for use with this boiler.
- * Do not attempt to mix components from different approved vent systems.
- * Do not obtain combustion air from within the building.
- * Do not install a barometric damper or draffhood on this boiler.
- * Do not attempt to use the vent system for this boiler with any other appliance.
- * Moisture and ice may form on the surfaces around the vent termination. To prevent deterioration, surfaces should be in good repair (sealed, painted, etc.)

A. Vent System Design

There are two basic ways to vent the BWC boiler:

- **Horizontal (“side wall”) Venting** - Vent system exits the building through an outside wall. Combustion air is obtained through a separate pipe from outside.
- **Vertical Venting** - Vent system exits the building through a roof. Combustion air is obtained through a separate pipe from outside.

A description of each of these venting options is listed in Tables 6.2a and 6.2b. For clarity, these vent options are numbered from 1 to 7. **One of the vent option columns in Table 6.2 must match the planned vent and air intake system exactly.** In addition, observe the following guidelines:

- 1) Approved vent systems - Use only one of the approved vent systems shown in Table 4. These systems are made of a special stainless steel alloy (AL29-4C) for protection against corrosive flue gas condensate. They are also designed to provide a gas tight seal at all joints and seams so that flue gas does not enter the building. Each approved vent system has a unique method for installation - do not attempt to mix components from different vent systems.
- 2) Maximum Vent and Air Intake Lengths - The maximum length of the vent air intake piping depends upon the vent option selected and the boiler size. See Table 6.2 for the maximum vent length. In addition to the maximum length of piping shown in Table 6.2, the following fittings may also be used:
 - Horizontal Vent Systems: One 90 deg. elbow
 - Horizontal Air Intake Systems: One 90 deg. elbow
 - Vertical Vent Systems: Two 90 deg. elbows
 - Vertical Air Intake Systems: Two 90 deg. elbows

If additional elbows are desired, the maximum allowable vent length must be reduced by the amount shown in Table 6.6 for each additional elbow used. Termination fittings are not counted when counting additional elbows.

Example:

A 3” vent system is planned for a horizontally vented BWC150 which has the following components:

*2 ft vertical pipe
1 90 elbow
5 ft horizontal pipe
1 90 elbow
3 ft horizontal pipe
1 45 elbow
4 ft horizontal pipe
1 termination elbow*

The Vent Option #1 column in Table 6.2a describes a horizontal direct vent system using 3" vent pipe. From this column, we see that a BWC150 may have a vent length of up to 55ft. The first 90 elbow and the termination elbow are not considered. From Table 6.6, the equivalent length of the 3" 45 elbow is 4ft and the equivalent length of the 3" 90 degree elbow is 5.5ft. The maximum allowable run of straight pipe on this system is therefore:

$$55\text{ft} - 4\text{ft} - 5.5\text{ft} = 40\text{ft}$$

Since the planned installation has only 14 ft of straight pipe, the planned vent length is acceptable.

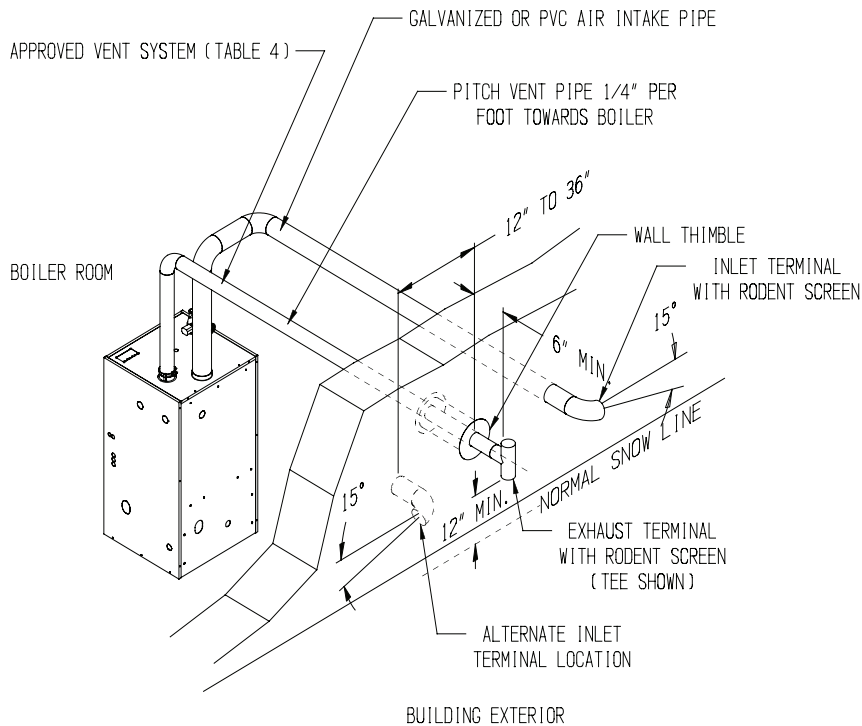

FIGURE 6.1: HORIZONTAL DIRECT VENTING (VENT OPTIONS 1,2)

- 3) Minimum Vent and Air Intake Lengths - Minimum vent length is 2ft. Minimum air inlet length is 2ft.
- 4) Permitted Terminals for Horizontal Venting (Vent Options 1,2) - The vent terminal is either a tee or an elbow supplied by the vent system manufacturer and equipped with a rodent screen. Vent system manufacturer's part numbers for these fittings are shown in Table 6.5. In some cases, the elbows and tees shown in Table 6.5 require separate rodent screens. When this is the case, vent manufacturer part numbers for these additional parts are shown in Table 6.5 along with the termination fitting.

The air intake fitting on a horizontal vent systems is always a 90 degree elbow with a rodent screen. This elbow is made out of the same material as the rest of the air inlet system (either galvanized or PVC) and is installed as shown in Figure 6.1.

- 5) Horizontal Vent and Air Intake Terminal Location - Observe the following limitations on the vent terminal location (also see Figure 6.3):
 - Vent terminals must be at least 1 foot from any door, window, or gravity inlet into the building.
 - Maintain the correct clearance and orientation between the vent and air intake terminals. The vent and air intake terminals must be at the same height and their center lines must be between 12 and 36 inches apart. Both terminals must be located on the same wall.
 - The bottom of the vent and air intake terminals must be at least 12" above the normal snow line. In no case should they be less than 12" above grade level.

- The bottom of the vent terminal must be at least 7 feet above a public walkway.
- Do not install the vent terminal directly over windows or doors.
- The bottom of the vent terminal must be at least 3 feet above any forced air inlet located within 10 feet.
- USA Only: A clearance of at least 4 feet horizontally must be maintained between the vent terminal and gas meters, electric meters, regulators, and relief equipment. Do not install vent terminal over this equipment. In Canada, refer to B149.1 Installation Code for clearance to meters, regulators and relief equipment.
- Do not locate the vent terminal under decks or similar structures.
- Top of vent terminal must be at least 5 feet below eaves, soffits, or overhangs. Maximum depth of overhang is 3 ft.
- Vent terminal must be at least 6 feet from an inside corner.
- Under certain conditions, water in the flue gas may condense, and possibly freeze, on objects around the terminal including on the structure itself. If these objects are subject to damage by flue gas condensate, they should be moved or protected.
- If possible, install the vent and air intake terminals on a wall away from the prevailing wind. Reliable operation of this boiler cannot be guaranteed if the terminal is subjected to winds in excess of 40 mph.
- Air intake terminal must not terminate in areas that might contain combustion air contaminants, such as near swimming pools. See Section IV for more information on possible contaminants.

TABLE 6.2a: SUMMARY OF HORIZONTAL VENTING OPTIONS

VENT OPTION #		1	2	3	4	5
CLASSIFICATION USED IN THIS MANUAL		HORIZONTAL DIRECT VENT	HORIZONTAL DIRECT VENT	(RESERVED FOR FUTURE USE)	(RESERVED FOR FUTURE USE)	(RESERVED FOR FUTURE USE)
ILLUSTRATED IN FIGURE		6.1	6.1			
VENT PIPE STRUCTURE PENETRATION		WALL	WALL			
AIR INTAKE PIPE STRUCTURE PENETRATION		WALL	WALL			
VENT PIPE SIZE		3"	4"			
AIR INTAKE PIPE SIZE		4"	4"			
MAXIMUM VENT PIPE LENGTH						
	BWC150	55 FT	N.R.			
	BWC225	N.R.	55 FT			
MAXIMUM INTAKE PIPE LENGTH						
	BWC150	60 FT	N.R.			
	BWC225	N.R.	60 FT			
EXHAUST TERMINAL		3" 90 ELBOW OR TEE	4" 90 ELBOW OR TEE			
AIR INTAKE TERMINAL		4" 90 ELBOW	4" 90 ELBOW			
VENT MATERIAL		APPROVED VENT SYSTEM SHOWN IN TABLE 6.5				
AIR INTAKE MATERIAL		GALVANIZED OR PVC				

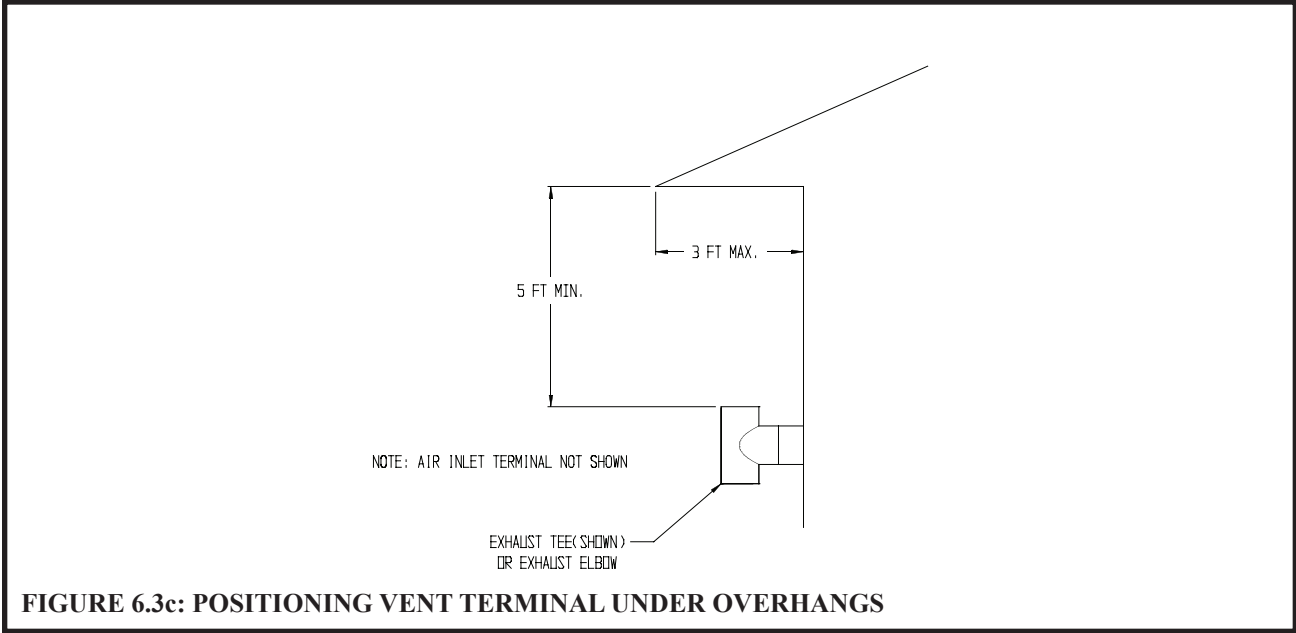
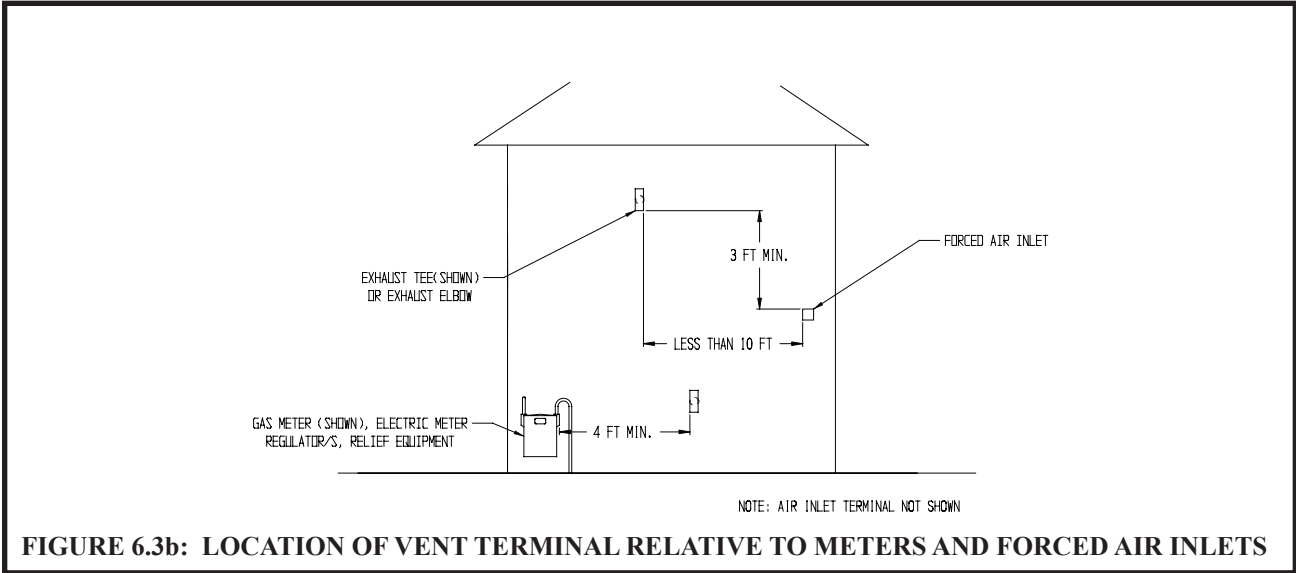
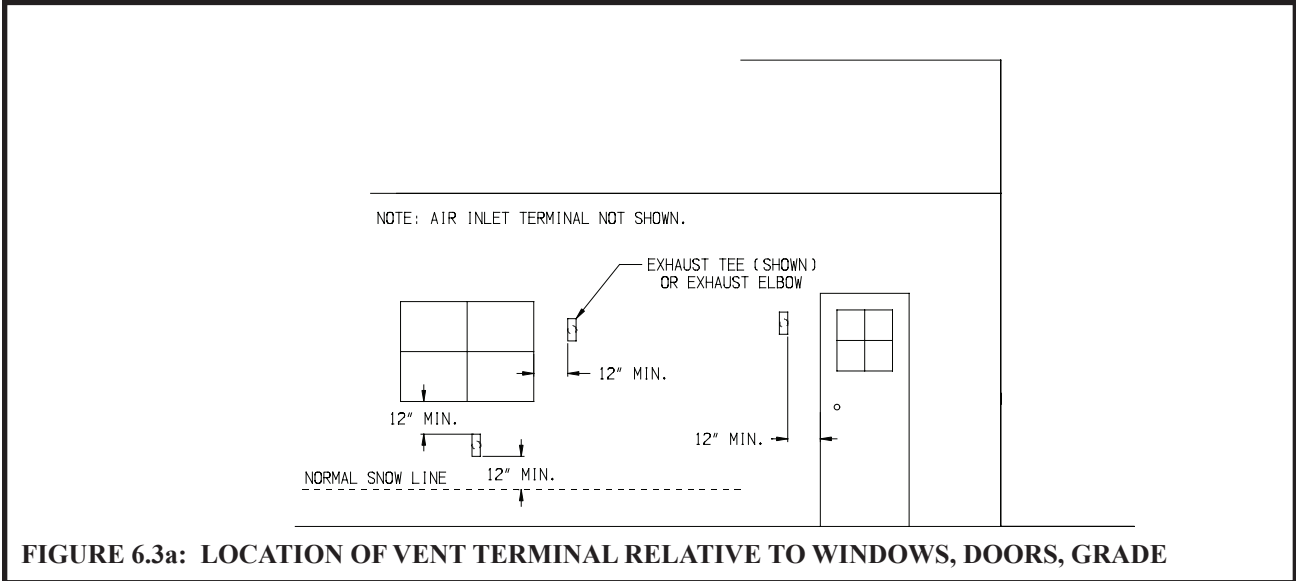

TABLE 6.2b: SUMMARY OF VERTICAL VENTING OPTIONS

VENT OPTION #		6	7
CLASSIFICATION USED IN THIS MANUAL		VERTICAL DIRECT VENT	VERTICAL DIRECT VENT
ILLUSTRATED IN FIGURE		6.4	6.4
VENT PIPE STRUCTURE PENETRATION		ROOF	ROOF
AIR INTAKE PIPE STRUCTURE PENETRATION		ROOF	ROOF
VENT PIPE SIZE		3"	4"
AIR INTAKE PIPE SIZE		4"	4"
MAXIMUM VENT PIPE LENGTH			
	BWC150	49.5 FT	N.R.
	BWC225	N.R.	47 FT
MAXIMUM INTAKE PIPE LENGTH			
	BWC150	52 FT	N.R.
	BWC225	N.R.	52 FT
EXHAUST TERMINAL		RODENT SCREEN BY VENT SYSTEM MANUFACTURER. SAME DIAMETER AS VENT SYSTEM. SEE TABLE 6.5.	
AIR INTAKE TERMINAL		4" 180 ELBOW	4" 180 ELBOW
VENT MATERIAL		APPROVED VENT SYSTEM SHOWN IN TABLE 6.5	
AIR INTAKE MATERIAL		GALVANIZED OR PVC	

"N.R." - Not recommended "N.A." - Not applicable

TABLE 6.5: PERMISSIBLE VENT SYSTEMS AND PRINCIPLE VENT COMPONENTS

MANUFACTURER	VENT SYSTEM	SIZE	WALL THIMBLES	HORIZONTAL TERMINATION	VERTICAL TERMINATION
HEAT FAB	SAF-T VENT EZ SEAL	3	7393GC 7393GCS 5391CI	ELBOW: 7314TERM TEE: 7390TEE	9392
		4	7493GC 7493GCS 5491CI	ELBOW: 7414TERM TEE: 7490TEE	9492
PROTECH SYSTEMS INC.	FASNSEAL	3	FSWT3	ELBOW: FSELB9003 + FSBS3 TEE: FSTT3	FSBS3
		4	FSWT4	ELBOW: FSELB9004 + FSBS4 TEE: FSTT4	FSBS4
Z-FLEX	SVE SERIES III ("Z-VENT III")	3	2SVSWTEF03	ELBOW: 2SVSTEX0390 TEE: 2SVSTTF03	24SVSTPF03
		4	2SVSWTEF04	ELBOW: 2SVEEWCF0490 + 2SVSTPF04 TEE: 2SVSTTF04	24SVSTPF04
METAL-FAB	CORR/GUARD	3	CGSWWPK(3")	ELBOW: CGSW90LTM(3") TEE: CGSWTTM(3")	CGSWTTM(3")
		4	CGSWWPK(4")	ELBOW: GSW90LTM(4") TEE: CGSWTTM(4")	CGSWTTM(4")

NOTE: See vent system manufacturer's literature for other part numbers that are required such as straight pipe, elbows, firestops and vent supports.

TABLE 6.6: VENT/ AIR INTAKE FITTING EQUIVALENT LENGTH

VENT FITTING	EQUIVALENT LENGTH (ft)
3" 90 ELBOW	5.5
3" 45 ELBOW	4.0
4" 90 ELBOW	8.0
4" 45 ELBOW	4.5

Read this only if the BWC boiler is replacing an existing boiler that is being removed from a common chimney. This section does not apply to the installation of a BWC boiler.

In some cases, when an existing boiler is removed from a common chimney, the common venting system may be too large for the remaining appliances. At the time of removal of an existing boiler, the following steps shall be followed with each appliance remaining connected to the common venting system placed in operation, while the other appliances remaining connected to the common venting system are not in operation.

- (a) Seal any unused openings in the common venting system.
- (b) Visually inspect the venting system for proper size and horizontal pitch and determine there is no blockage or restriction, leakage, corrosion and other deficiencies which could cause an unsafe condition.
- (c) Insofar as practical, close all building doors and windows and all doors between the space in which all the appliances remaining connected to the common venting system are located and other spaces of the building. Turn on clothes dryers and any appliance not connected to the common venting system. Turn on any exhaust fans, such as range hoods and bathroom exhausts, so they will operate at maximum speed. Do not operate a summer exhaust fan. Close fireplace dampers.
- (d) Place in operation the appliance being inspected. Follow the lighting instructions. Adjust thermostat so the appliance will operate continuously.
- (e) Test for spillage at the draft hood relief opening after 5 minutes of main burner operation. Use the flame of a match or candle, or smoke from a cigarette, cigar, or pipe.
- (f) After it has been determined that each appliance remaining connected to the common venting system properly vents when tested as outlined above, return doors, windows, exhaust fans, fireplace dampers and any other gas-burning appliances to their previous condition of use.
- (g) Any improper operation of the common venting system should be corrected so the installation conforms with the National Fuel Gas Code, ANSI Z223.1. When re-sizing any portion of the common venting system, the common venting system should be re sized to approach the minimum size as determined using the appropriate tables in Part 11 of the National Fuel Gas Code, ANSI Z223.1.

WARNING

NEVER COMMON VENT A BWC BOILER WITH OTHER APPLIANCES

C. Vent / Intake System Assembly

1) General Assembly Notes:

- a) Where the use of “silicone” is called for in the following instructions, use GE RTV 106 for the vent collar. Air inlet piping sections are sealed with any general-purpose silicone sealant such as GE RTV102. PVC air inlet piping sections are connected with PVC cement.
- b) Longitudinal welded seams should not be placed at the bottom of horizontal sections of exhaust pipe.
- c) Do not drill holes in vent pipe.
- d) Do not attempt to mix vent components of different vent system manufacturers.
- e) In some cases, there are differences between the vent system installation instructions in this manual and those in the vent system manufacturer’s manual. Where such differences exist, this manual takes precedence over the vent system manufacturer’s manual.

CAUTION

Vent systems made by Heat Fab, Protech, and Z-Flex rely on gaskets for proper sealing. When these vent systems are used, take the following precautions:

- **Make sure that gasket is in position and undamaged in the female end of the pipe.**
- **Make sure that both the male and female pipes are free of damage prior to assembly.**
- **Only cut vent pipe as permitted by the vent manufacturer in accordance with their instructions. When pipe is cut, cut end must be square and carefully deburred prior to assembly.**

3) Assembly of Metal-Fab Corr/Guard Vent System:

a) Corr/Guard General Notes:

- Do not cut Corr/Guard vent components.
- Refer to Corr/Guard installation instructions for proper methods of support.
- Orient Corr/Guard components so that the males ends of all fittings point in the direction of the boiler.

- b) Start assembly of the vent system at the boiler. Remove the hose clamp shipped on the BWC vent collar. Bend the three hose clamp tabs on this collar outward slightly.
- c) Clean the exterior of the male end of the first piece of pipe and the inside of the vent collar on the boiler. Remove dirt, grease, and moisture from the surfaces to be sealed. Dry surfaces or allow to dry thoroughly.
- d) On the male end of the pipe, apply a 1/4" wide bead of silicone approximately 1/2" from the end of the pipe (Fig 7.47).
- e) Insert the male end of the pipe into the boiler vent collar until it bottoms out.
- f) Apply an additional bead of silicone over the outside of the joint and smooth out.
- g) Replace and tighten the clamp on the vent collar.
- h) Assemble remaining Corr/Guard components in accordance with the Corr/Guard installation instructions.
- i) Allow the silicone to cure per the silicone manufacturer's instructions before operating the boiler.

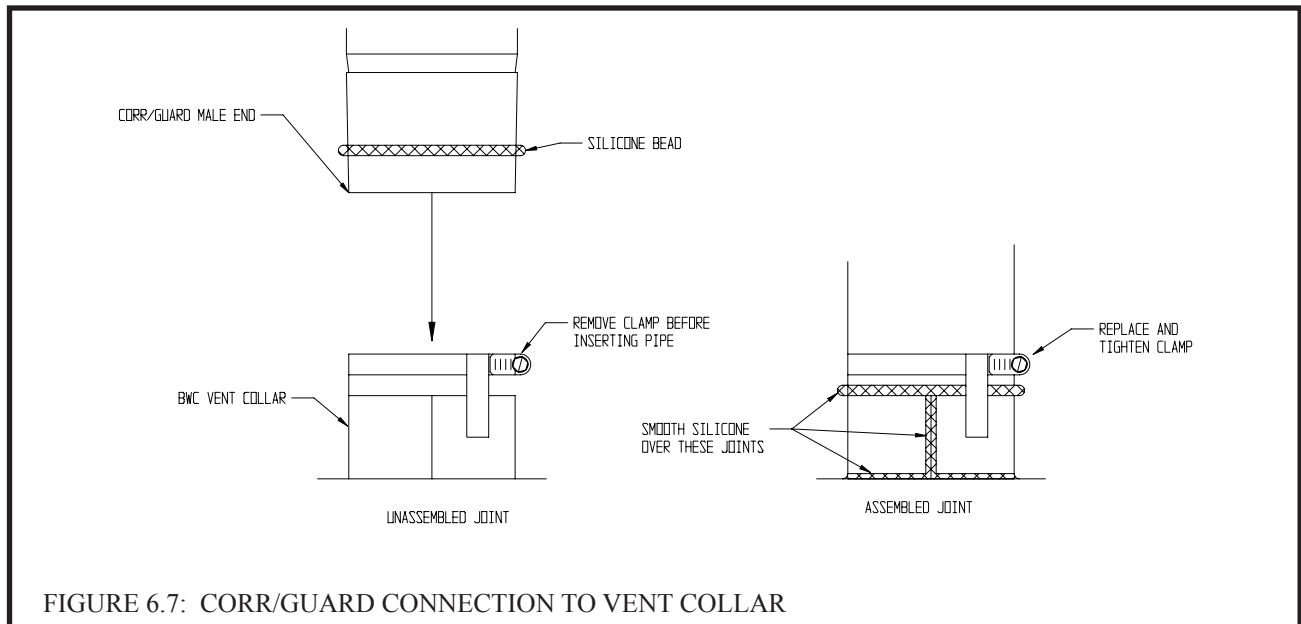

3) Assembly of Z-Flex Z-Vent III:

a) General Notes:

- Non-expanded ends of SVE Series III piping sections may be cut using aviation snips or a 24 thread per inch hacksaw. File or sand the cut end smooth before assembling. Expanded ends may be cut to adapt the SVE series III to the vent collar or Crown coaxial terminal. See the following instructions.
 - Support horizontal piping sections at intervals of 48" or less.
 - Vertical venting systems must be supported by at least one Z-Flex fire stop. An additional vertical support is required after any offset and as required by the Z-Vent III installation instructions.
- b) Start assembly of the vent system at the boiler. Remove the hose clamp shipped on the BWC vent collar. Bend the three hose clamp tabs on this collar outward slightly.
- c) Clean the exterior of the male end of the first piece of pipe and the inside of the vent collar on the boiler. Remove dirt, grease, and moisture from the surfaces to be sealed. Dry surfaces or allow to dry thoroughly.
- d) On the male end of the pipe, apply a 1/4" wide bead of high temperature silicone approximately 1/2 inch from the male end of the pipe. Apply 1/4" beads of silicone along both sides of the longitudinal seam (Fig. 6.8).
- e) Insert the male end of the pipe into the boiler vent collar until it bottoms out.
- f) Apply an additional bead of silicone over the outside of the joint and smooth out.
- g) Replace and tighten the clamp on the vent collar.
- h) The female end of each Z-Vent III component has a silicone sealing gasket. Examine all vent components to insure that the gasket integrity has remained during shipping. Gaskets must be in the proper position or flue gas could leak resulting in carbon monoxide poisoning.
- i) Align the second piece of pipe with the first and push them together as far as they will go, but not less than 1-3/4".
- j) Tighten gear clamp to a minimum torque of 40 in-lbs and a maximum of 50 in-lbs.
- k) Repeat Steps (h) – (j) for the remaining Z-Vent III components.
- l) In horizontal vent systems, a locking band or gear clamp must be used at either side of the wall penetration to prevent shifting of the vent system in and out of the wall. This applies to both combustible and non-combustible walls.
- n) Allow the silicone to cure per the silicone manufacturer's instructions before operating the boiler.

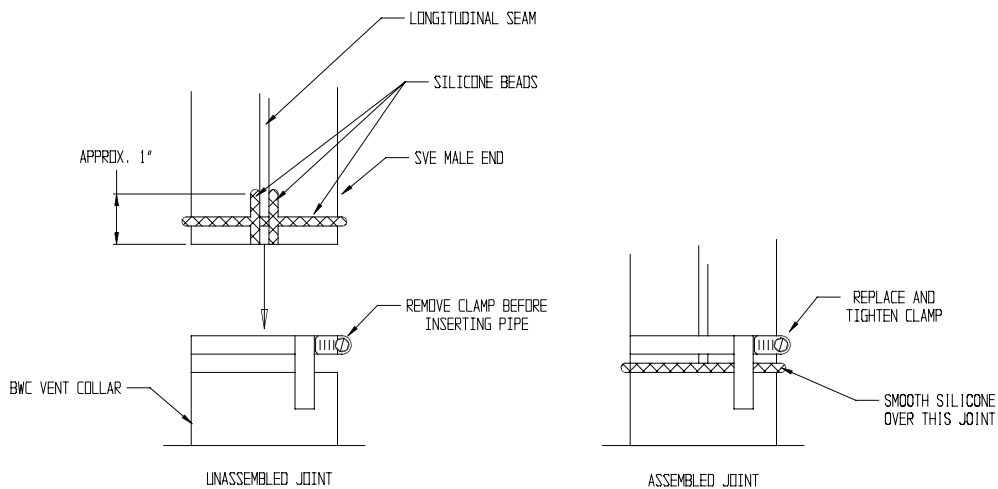

FIGURE 6.8: Z-VENT III CONNECTION TO VENT COLLAR

4) Assembly of Heat Fab Saf-T Vent EZ Seal:

a) Saf-T Vent General Notes:

These instructions cover the installation of Saf-T Vent EZ Seal. Saf-T Vent EZ Seal piping has integral gaskets installed in the female ends of the pipe which seal the joints.

- In general, Saf-T Vent pipe sections may not be cut. Exceptions to this are the Saf-T Vent slip connector and connections to the boiler vent collar. In these cases, use a sharp pair of aviation snips, an abrasive cut-off, or a plasma cutter. See the Saf-T Vent instructions for information on cutting the slip connector.
- Orient Saf-T Vent components so that the arrows on the piping labels are in the direction of flue gas flow.
- Support horizontal piping sections at intervals of 6 feet or less.
- Vertical venting systems must be supported by at least one Heat Fab support. An additional vertical support is required after any offset.

b) Connection to Boiler – Start assembly of the vent system at the boiler. Remove the hose clamp shipped on the BWC vent collar. Bend the three hose clamp tabs on this collar outward slightly. Cut the male “spigot” off of the first piece of pipe (Fig 6.9). If necessary, crimp the cut end of the pipe so that it can be inserted at least 1” into the collar. Clean the exterior of the male end of the first piece of pipe and the inside of the vent collar on the boiler with an alcohol pad. On the male end of the pipe, apply a ¼” wide bead of high temperature silicone approximately ½ inch from the male end of the pipe. Also apply a ¼” bead of silicone along the first 2 ½” of the longitudinal weld. Insert the male end of the pipe into the boiler vent collar until it bottoms out. Apply an additional bead of silicone over the outside of the joint and smooth out (Fig 6.9). Replace and tighten the clamp on the vent collar.

c) Assembly of Saf-T Vent EZ Seal Vent Components - Clean the male end of the next piece of pipe with an alcohol pad and make sure that it is free of burrs. Check the female end of the first piece of pipe to make sure that the gasket is in place and is undamaged. Using a slight twisting motion, insert the male end of the second fitting into the female end of the first fitting, taking care not to dislodge or cut the factory gasket. In extremely arid conditions, it may be easier to assemble these fittings if the gasket is moistened with water prior to assembly. Bend the locking tabs over the locking ring on the adjacent piece of pipe. Repeat these steps for the remaining Saf-T-Vent components.

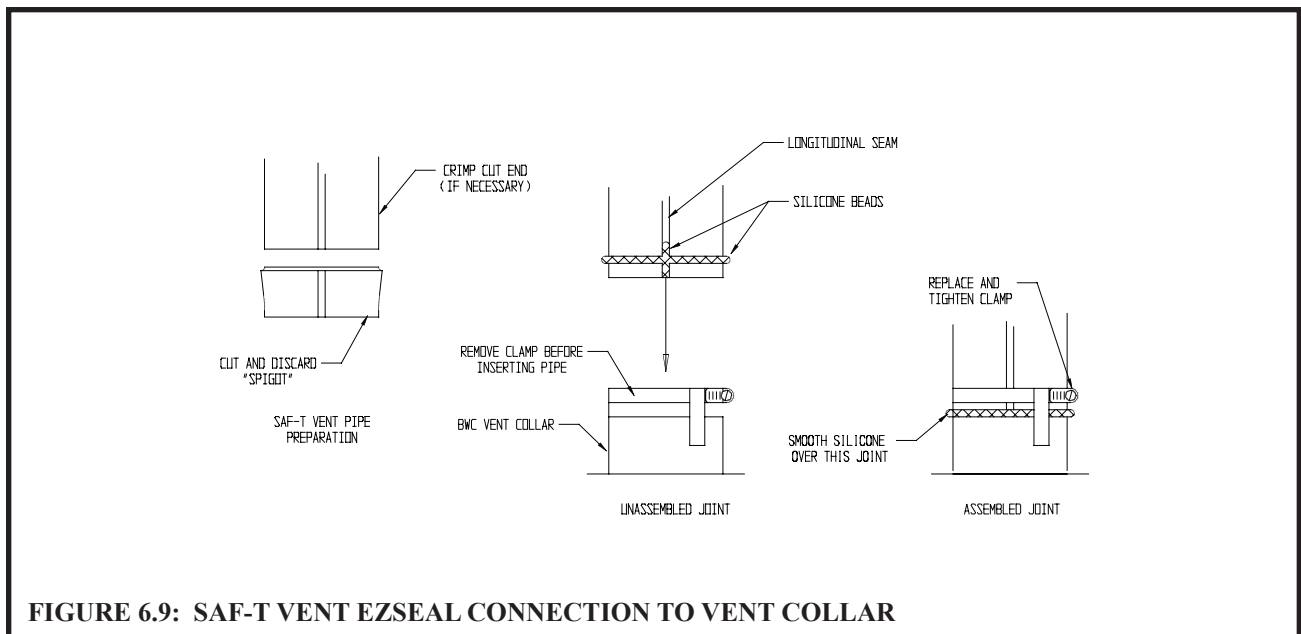

FIGURE 6.9: SAF-T VENT EZSEAL CONNECTION TO VENT COLLAR

5) Assembly of Protech FasNSeal

a) FasNSeal General Notes:

- Do not cut 4" FasNSeal pipe. Consult FasNSeal instructions for method of cutting other 3" pipe.
- Orient FasNSeal vent components so that the arrows on the piping labels are in the direction of flue gas flow.
- Support horizontal piping sections at intervals of 6 feet or less.
- Vertical venting systems must be supported by at least one FasNSeal support. An additional vertical support is required after any offset.

- b) Remove the hose clamp shipped on the BWC vent collar. Bend the three hose clamp tabs on this collar outward slightly. Clean the exterior of the male end of the first piece of pipe and the inside of the vent collar on the boiler. Remove dirt, grease, and moisture from the surfaces to be sealed. On the male end of the pipe, apply a 1/4" wide bead of high temperature silicone approximately 1/4 inch from the male end of the pipe. Insert the male end of the pipe into the boiler vent collar until it bottoms out. Apply an additional bead of silicone over the outside of the joint and the seams on the vent collar and smooth out (Fig 6.10). Replace and tighten the clamp on the vent collar.
- c) All other joints in the FasNSeal venting system rely on a gasket in the female end of the pipe for a proper seal.
- d) Align the longitudinal seam of both pipes. Insert the male end of the second pipe into the female end of the first pipe until the bead on the male end contacts the flare on the female end.
- e) Tighten the locking band with a nut driver.
- f) Repeat (d) and (e) for the remaining FasNSeal components.
- g) Allow the silicone to cure per the silicone manufacturer's instructions before operating the boiler.

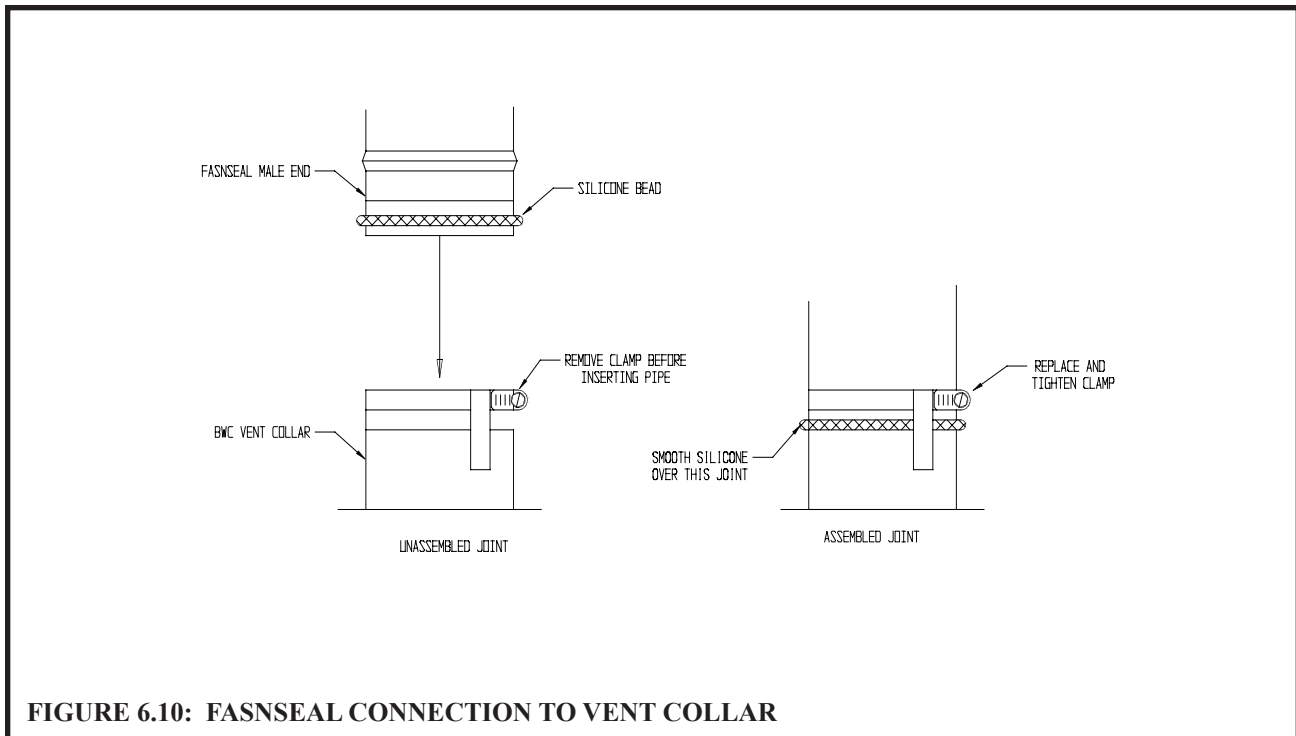

6) Assembly of the air intake system:

- a) Assemble the air intake system using either galvanized or PVC pipe.
- b) If PVC piping is used, use PVC cement to assemble the PVC intake system components.
- c) If galvanized piping is used, use at least two sheet metal screws per joint. Seal the outside of all joints.

- d) 4” galvanized smoke pipe will fit inside the inlet collar on the BWC boiler. Depending upon the exact OD of the pipe used, it may be necessary to crimp this pipe. Secure with a single #10 sheet metal screw through the hole in the inlet collar and seal the outside of the joint with silicone. If PVC is used for the intake system, use a short piece of 4” galvanized pipe to connect the PVC to the boiler. Silicone the outside of the joint between the PVC and galvanized pipe.
 - e) Two 90-degree elbows may be used to make the 180-degree air intake termination elbow used on vertical direct vent installations.
- 7) Rodent Screens - A rodent screen is provided with the BWC boiler for installation in the air inlet terminal.
- 8) Condensate Drain Line - All condensate which forms in the boiler or vent system collects in the sump under the heat exchanger and leaves the boiler through the condensate trap. This trap allows condensate to drain from the sump while retaining flue gases in the boiler. A length of drain hose is supplied with the boiler and is connected to the trap as shown in Figure 6.11. This hose may be routed through the back of the boiler or to either side through the knockouts provided. Route this hose to a drain or other suitable point for disposal. Note the following when disposing of the condensate:
- a) If the condensate drain line must be extended, construct the extension from PVC or CPVC pipe. Insert the hose provided with the boiler into the end of the extension as shown in Figure 6.11.
 - b) Condensate is slightly acidic. Do not use metallic pipe or fittings in the condensate drain line. Do not route the drain line through areas that could be damaged by leaking condensate.
 - c) Some jurisdictions may require that the condensate be neutralized before being disposed of. Dispose of condensate in accordance with local codes.
 - d) Do not route, or terminate, the condensate drain line in areas subjected to freezing temperatures.
 - e) If the point of condensate disposal is above the trap, it will be necessary to use a condensate pump to move the condensate to the drain. In such cases, select a condensate pump that is approved for use with condensing furnaces. If overflow from this pump would result in property damage, select a pump with an overflow switch and use this switch to shut down the boiler. Alternatively, if heat is a necessity, use the overflow switch to trigger an alarm.
 - f) Do not attempt to move the trap from the location shown in Figure 6.11. Do not attempt to substitute another trap for the one provided with the boiler.
 - g) The vent shown in Figure 6.11 must be left open for the trap to work properly.

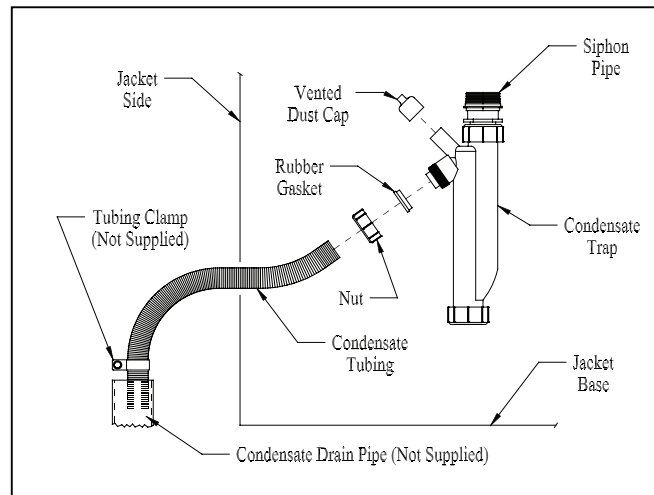

FIGURE 6.11: CONDENSATE PIPING ARRANGEMENT

WARNING

BOILER CONDENSATE IS CORROSIVE. ROUTE CONDENSATE DRAIN LINE IN A MANNER SUCH THAT ANY CONDENSATE LEAKAGE WILL NOT CAUSE PROPERTY DAMAGE.

SOME JURISDICTIONS MAY REQUIRE THAT CONDENSATE BE NEUTRALIZED PRIOR TO DISPOSAL.

PAGE
INTENTIONALLY
LEFT
BLANK

PAGE
INTENTIONALLY
LEFT
BLANK

PAGE
INTENTIONALLY
LEFT
BLANK

VII Gas Piping

Gas piping to the boiler must be sized to deliver adequate gas for the boiler to fire at the nameplate input at an inlet pressure between the minimum and maximum values shown on the rating plate. For more information on gas line sizing, consult the utility or the *National Fuel Gas Code*.

Figure 7.1 shows typical gas piping connection to the BWC boiler. Depending upon the exact boiler model, the gas connection may be on either the back or RH side of the boiler. A sediment trap must be installed upstream of all gas controls. Install the factory provided manual shut-off valve outside the jacket with a ground joint union as shown.

The boiler and its gas connection must be leak tested before placing the boiler in operation. When doing this, the boiler and its individual shut-off must be disconnected from the rest of the system during any pressure testing of that system at pressures in excess of 1/2 psi. When pressure testing the gas system at pressures of 1/2 psi or less, isolate the boiler from the gas supply system by closing its individual manual shut-off valve.

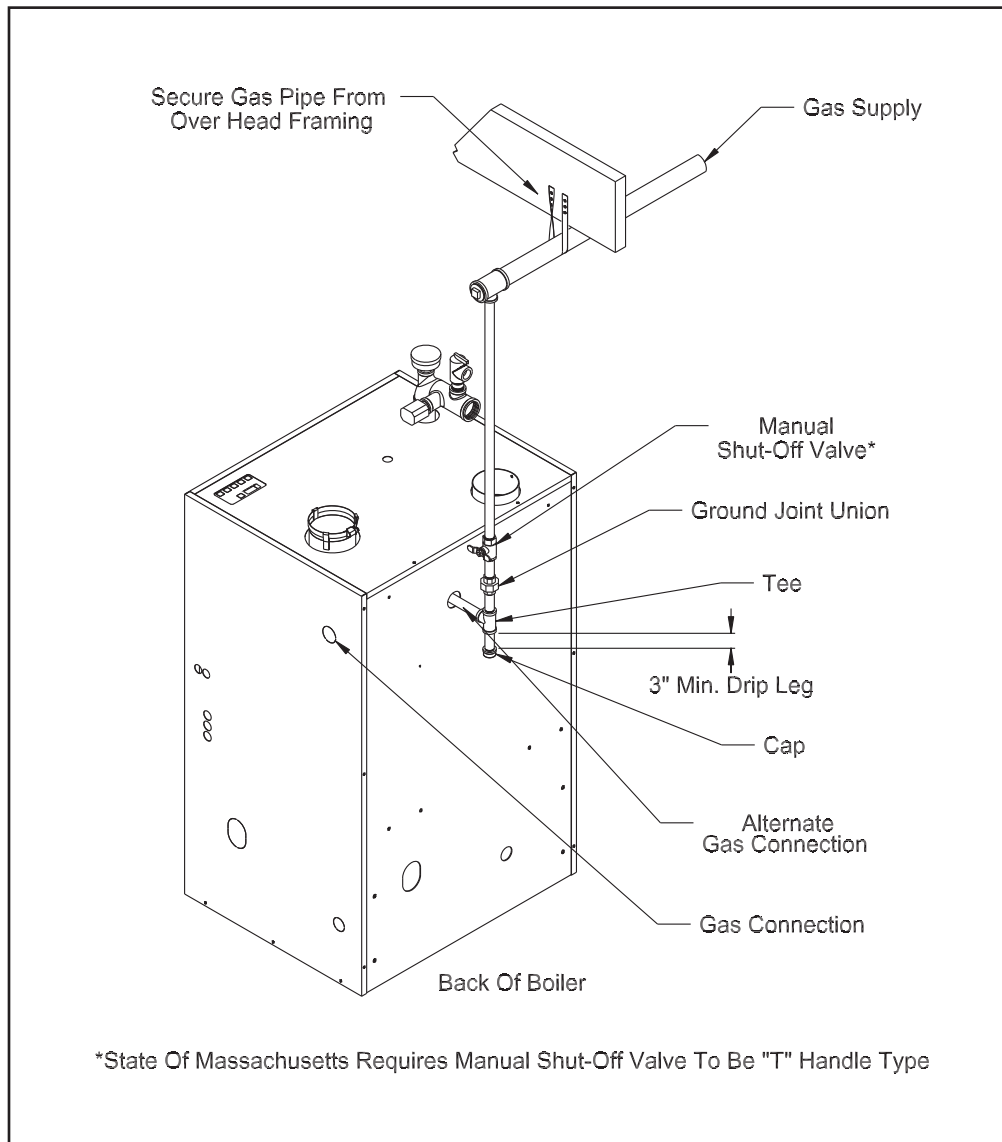

Figure 7.1: Gas Connection To Boiler

VIII System Piping

A. General System Piping Precautions

WARNING

INSTALL BOILER SO THAT THE GAS IGNITION SYSTEM COMPONENTS ARE PROTECTED FROM WATER (DRIPPING, SPRAYING, RAIN, ETC) DURING APPLIANCE OPERATION AND SERVICE (CIRCULATOR REPLACEMENT, ETC).

CAUTION

THE HEAT EXCHANGER USED IN THE BWC IS MADE FROM A SPECIAL ALUMINUM ALLOY. FAILURE TO TAKE THE FOLLOWING PRECAUTIONS COULD RESULT IN SEVERE BOILER DAMAGE.

- BEFORE CONNECTING BOILER, MAKE SURE THAT THE SYSTEM IS FREE OF SEDIMENT, FLUX AND ANY RESIDUAL BOILER WATER ADDITIVES. FLUSH THE SYSTEM IF NECESSARY TO ENSURE THAT THESE CONTAMINATES ARE REMOVED.
- DO NOT CONNECT THIS BOILER TO A SYSTEM THAT IS SUBJECT TO REGULAR ADDITIONS OF MAKEUP WATER OR ONE WHICH EMPLOYS RADIANT TUBING WITHOUT AN OXYGEN BARRIER.
- DO NOT ADD ANTIFREEZE OR OTHER BOILER WATER TREATMENT CHEMICALS EXCEPT THOSE LISTED IN PART X OF THIS MANUAL.
- MAINTAIN THE PRESSURE IN THE BOILER AT A MINIMUM OF 12 PSI.
- DESIGN SYSTEM TO ENSURE THAT THE FLOW FALLS WITHIN THE LIMITS CALLED FOR IN TABLE 8.1.

B. System Design

Proper operation of the BWC boiler requires that the water flow through the boiler remain within the limits shown in Table 8.1 any time the burner is firing. Failure to maintain the flow within these limits could result in erratic operation or premature boiler failure.

There are two basic methods that can be used to pipe the BWC boiler. Method #1 is almost always preferred. The instructions on the following pages describe these methods for piping BWC boilers and explain how to size the circulator and piping. Additional information on hydronic system design may be found in Installation of Residential Hydronic Systems (Pub. #200) published by the Hydronics Institute in Berkeley Heights, NJ.

TABLE 8.1: FLOW REQUIREMENTS THROUGH BOILER

BOILER MODEL	MIN. REQUIRED FLOW (GPM)	MAX. ALLOWABLE FLOW (GPM)
BWC150	8	15
BWC225	9	23

Method 1: Primary/Secondary Piping - Boiler in Secondary Loop

This method can be used in heat-only applications as shown in Figure 8.2 or with an indirect water heater as shown in Figure 8.3. This method relies on primary/secondary pumping to ensure that the required flow is always maintained through the boiler. In this system, the flow rate through the boiler is completely independent of the flow rate through the heating system. Use the following guidelines to ensure that the boiler will have the required flow shown in Table 8.1 regardless of the flow in the heating system.

- 1) Primary Loop Piping - Size the primary circulator and piping to obtain the design flow rate through the heating system as you would on any other heating system. All piping between the expansion tank and secondary connection tees must be at least as large as that shown in Table 8.5, column (a). In order to keep the flow rates in the primary and secondary loops independent of each other, provide at least 8 diameters of straight pipe upstream of the first secondary tee and 4 diameters downstream of the second secondary tee. Keep the distance between the expansion tank and the first secondary tee as short as practical.
- 2) Secondary Loop (“Boiler Loop”) Piping – All piping must be the size shown for the boiler in Table 8.5, column (a). To size the circulator:
 - a) Select one of the boiler water flow rates shown in Table 8.5, column (b) for the boiler being installed. When selecting the required boiler flow rate, keep in mind that if the flow rate in the primary loop exceeds the flow rate through the boiler, it will not be possible to obtain a 180F supply temperature in the primary loop. This is because the supply water exiting the boiler will be mixed with cooler system return water before entering the radiation.
 - b) Count all fittings in the planned secondary loop (the secondary loop consists of the shaded piping in Figure 8.4a). In doing so, do not count the secondary connection tees, unions, or the fittings supplied with the boiler (these have already been accounted for).
 - c) Using Table 8.7, find the equivalent lengths of all fittings in the secondary loop. Total these equivalent lengths and add them to the total length of planned straight pipe in the secondary loop. The result is the total equivalent length of the secondary loop.
 - d) Using Table 8.5, find the boiler size being installed and select a boiler secondary circulator that shows a “maximum equivalent length” (column e) in excess of the total equivalent length calculated in Step (c).
- 3) Indirect Water Heater Loop Piping (If Indirect Water Heater is Used) – All piping must be the size shown in Table 8.6, column (a). If the indirect water heater connections are smaller than the pipe size called for in column (a), reduce the pipe size at the indirect water heater connections. To size the circulator:
 - a) Count all fittings in the planned Indirect Water Heater Loop (the indirect water heater loop consists of the shaded piping in Figure 8.4b). In doing so, you will be counting some piping and fittings which are common to the heating system secondary (“boiler loop”) piping and which were counted in Step 2a above. Do not count the elbows or fittings supplied with the boiler.
 - b) Using Table 8.7, find the equivalent lengths of all fittings in the indirect water heater loop. Total these equivalent lengths and add them to the total length of planned straight pipe in the indirect water heater loop. The result is the total equivalent length of the indirect water heater loop.
 - c) Using Table 8.6, find the boiler size being installed and select an indirect water heater loop circulator that shows a “maximum equivalent length” (column f) in excess of the total equivalent length calculated in Step b.

Example – Assume that a BWC150 is to be installed in a heating system along with a Crown MS-40 indirect water heater. A total of 15 ft of straight pipe will be installed between the boiler and the primary loop. A total of 20 ft of straight pipe will be installed between the boiler and the indirect water heater. Fittings are arranged as shown in Figure 8.3. The MS-40 requires a flow rate of 8 GPM and has a head loss of 3.0 ft.

Total fittings in Secondary loop (“boiler loop”):

7 90 Elbows
2 Runs of Tees
1 Swing Check
2 Isolation Valves

Note: Unions, Secondary Connection Tees, and factory supplied fittings are ignored.

Calculate total equivalent length from Table 8.7:

15ft Straight Pipe + 7 Elbows x 3.75 + 2 Runs of Tees x 2.5 + 1 Swing Check x 10 + 2 valves x 0.8 = 57.85
Equivalent Feet Straight Pipe. From Table 8.5, we see that a Taco 007 will pump 8 GPM through a BWC150 with 148 equivalent feet of pipe, so Taco 007 is OK.

Total fittings in Indirect Water Heater Loop:

6 90 Elbows
2 Turns in Tees
1 Swing Check
2 Isolation Valves

Calculate total equivalent length from Table 8.7:

20 Straight Pipe + 6 Elbows x 3.75 + 2 Turns in Tees x 8 + 1 Swing Check x 10 + 2 valves x 0.8 = 70.1 Equivalent Feet Straight Pipe. From Table 8.6, we see that smallest circulator which will pump at 8 GPM through a BWC150 with 70.1 equivalent feet and an indirect water heater pressure drop of 3 ft is a Taco 0010.

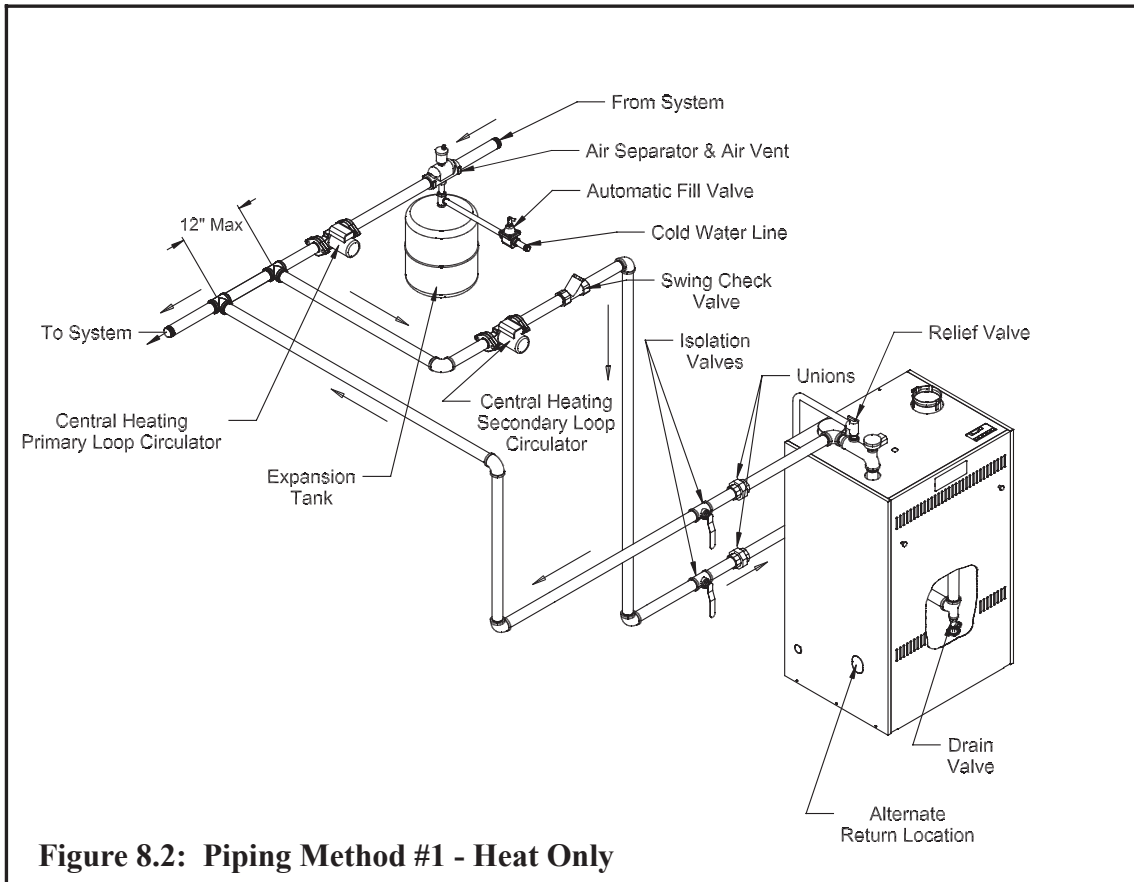

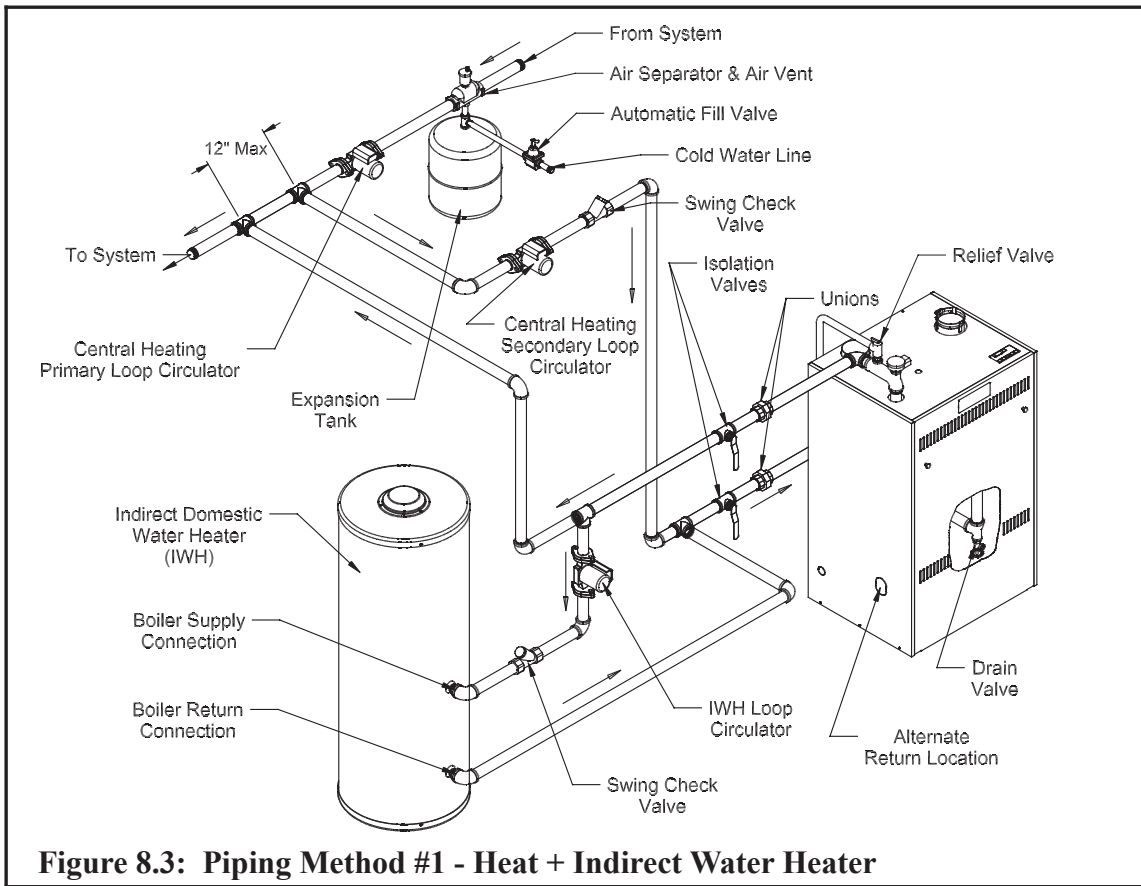

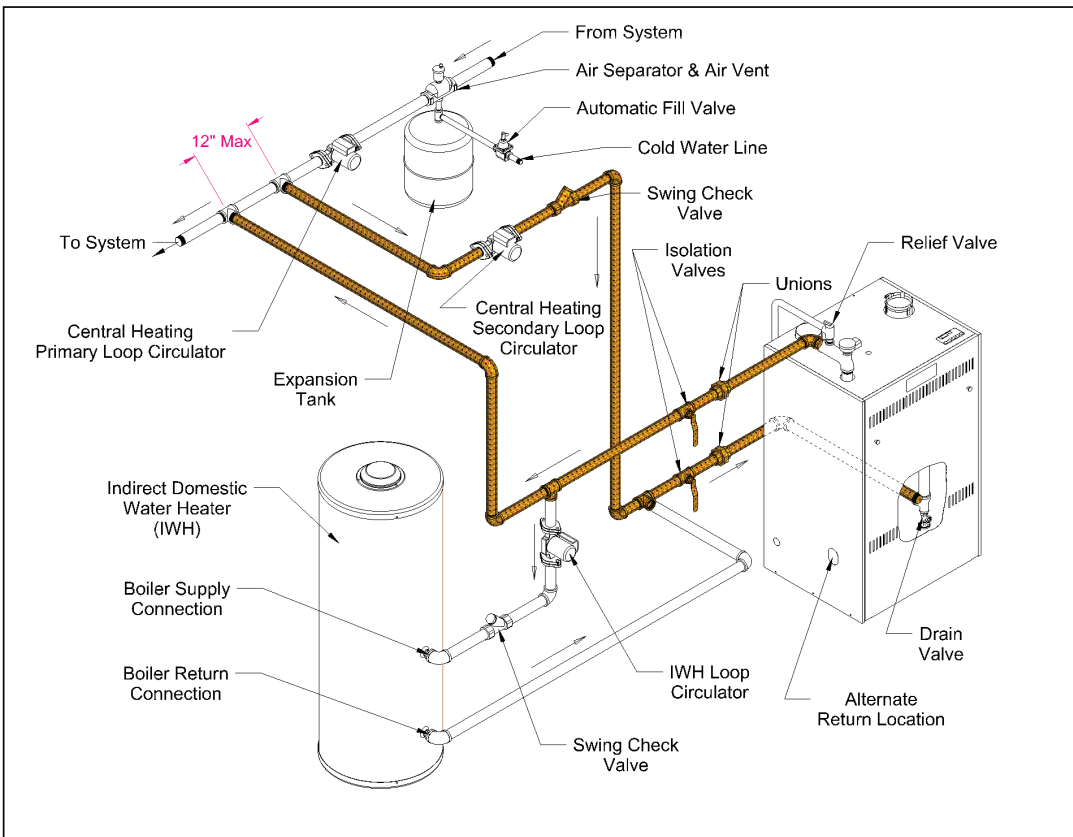

Figure 8.4a: Piping Method #1 - Secondary Loop Piping (Shaded)

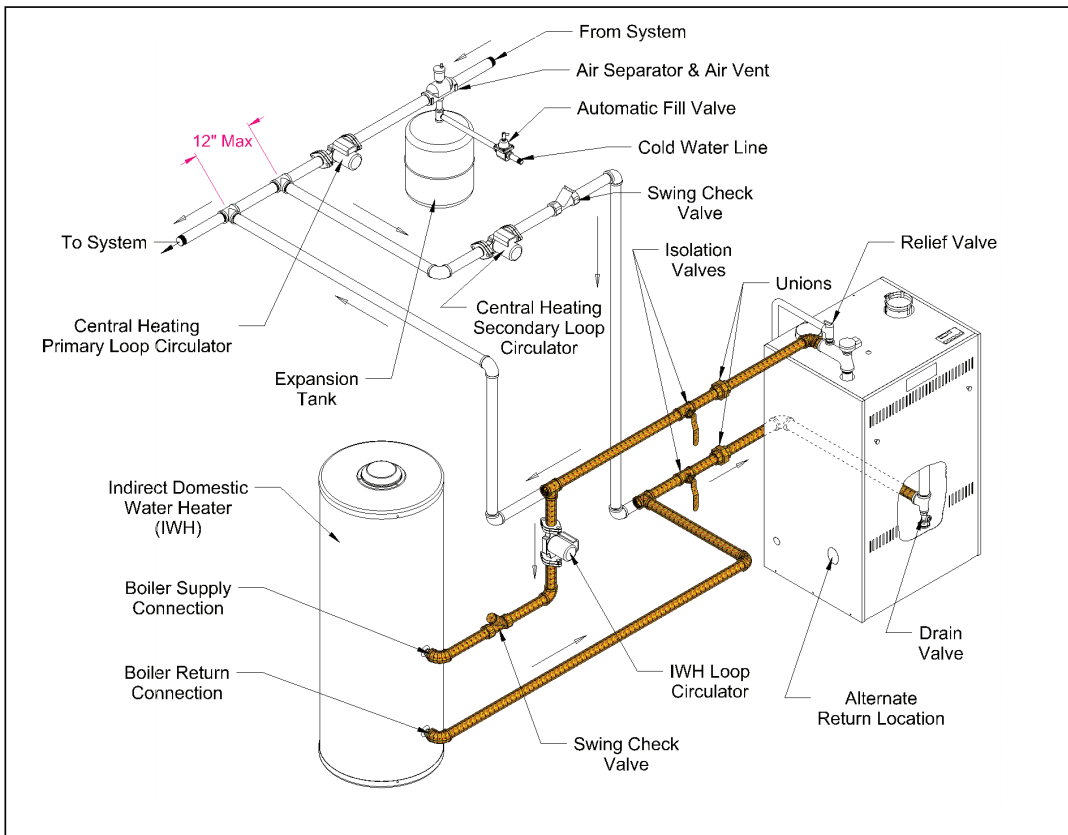

Figure 8.4b: Piping Method #1 - Indirect Water Heater Loop Piping (Shaded)

TABLE 8.5: PIPE AND CIRCULATOR SIZING FOR BOILER LOOP

BOILER MODEL	(a) PIPE SIZE (in NPT)	(b) FLOW (GPM)	(c) TEMP RISE (F)	(d) CIRCULATOR MODEL	(e) BOILER LOOP MAX EQUIVALENT LENGTH (ft)
BWC150	1 1/4	8.0	34	Taco 007	185
BWC150	1 1/4	8.0	34	Taco 0010	254
BWC150	1 1/4	12.0	22	Taco 0010	75
BWC225	1 1/4	12.0	34	Taco 007	58
BWC225	1 1/4	12.0	34	Taco 0010	103
BWC225	1 1/4	18.0	23	Taco 0014	52

TABLE 8.6: PIPE AND CIRCULATOR SIZING FOR INDIRECT WATER HEATER LOOP

BOILER MODEL	(a) PIPE SIZE (in NPT)	(b) FLOW (GPM)	(c) MAX. I.W.H. PRESSURE DROP (ft HEAD)	(d) CROWN INDIRECT WATER HEATERS	(e) CIRCULATOR MODEL	(f) I.W.H. LOOP MAX EQUIVALENT LENGTH (ft)
BWC150	1 1/4	8.0	3.0	MS-26, MS-40 MSH-40H MT040GBR - MT080GBR	Taco 007	81
BWC150	1 1/4	8.0	3.0	MS-26, MS-40 MSH-40H MT040GBR - MT080GBR	Taco 0010	150
BWC150	1 1/4	8.0	5.0	MS-53, MS-79 MSH-53H*	Taco 0010	81
BWC225	1 1/4	9.0	3.0	MT040GBR - MT080GBR	Taco 007	91
BWC225	1 1/4	9.0	5.0	MS-26, MS-40, MS-53 MSH-40H, MSH-53H MS-119*	Taco 0010	91
BWC225	1 1/4	10.6	3.0	MT120GBC*	Taco 0010	73

* Catalog rating of indirect water heater will not be achieved due to inadequate boiler output.

TABLE 8.7: FITTING EQUIVALENT LENGTHS

FITTING	PIPE SIZE	EQUIVALENT LENGTH (ft)
90 ELBOW	1 1/4	3.75
TURN IN TEE	1 1/4	8.00
RUN OF TEE	1 1/4	2.50
SWING CHECK	1 1/4	10.00
GATE VALVE	1 1/4	0.80

Method 2: Direct Connection to Heating System (Generally NOT Recommended)

The BWC can be connected directly to the heating system as is done with conventional boilers (Figure 8.8). If this is done, the flow rate through the boiler will equal the flow rate through the system. The flow rate through the system must therefore always remain within the limits shown in Table 8.1. For this reason, the pressure drop through the entire system must be known, added to the boiler pressure drop, and a circulator selected which will provide the required flow at the total calculated pressure drop.

This method is generally not recommended because it is often very difficult to accurately calculate the pressure drop through the system. In replacement installations, it may be impossible to get an accurate measurement of the amount of piping and number of fittings in the system. In addition, if the system is zoned, the system flow may drop well below the minimum required when only one zone is calling for heat.

The one advantage to this method is its installation simplicity. It may make sense to use this method when the boiler is to be installed with a new single zone system having a low-pressure drop. Pressure drop curves for the BWC Series boilers are shown in Figure 8.9. Calculation of the system pressure drop, and selection of the circulator, must be performed by someone having familiarity with pressure drop calculations, such as an HVAC engineer.

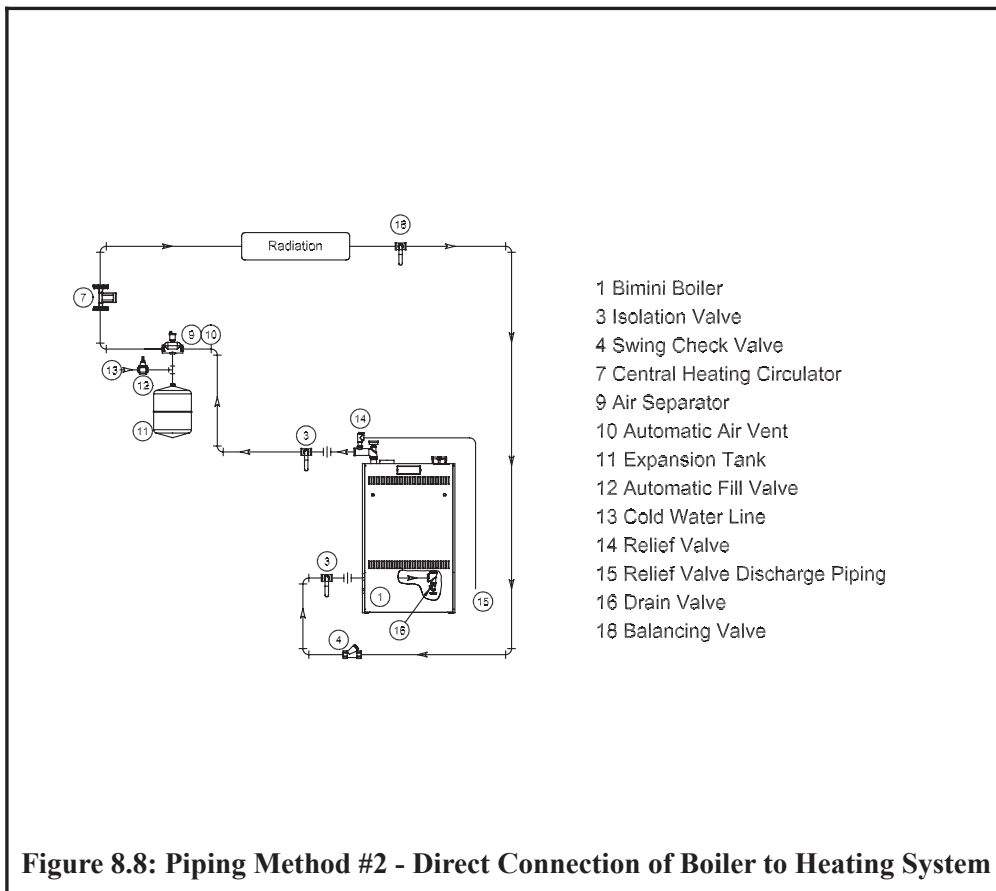

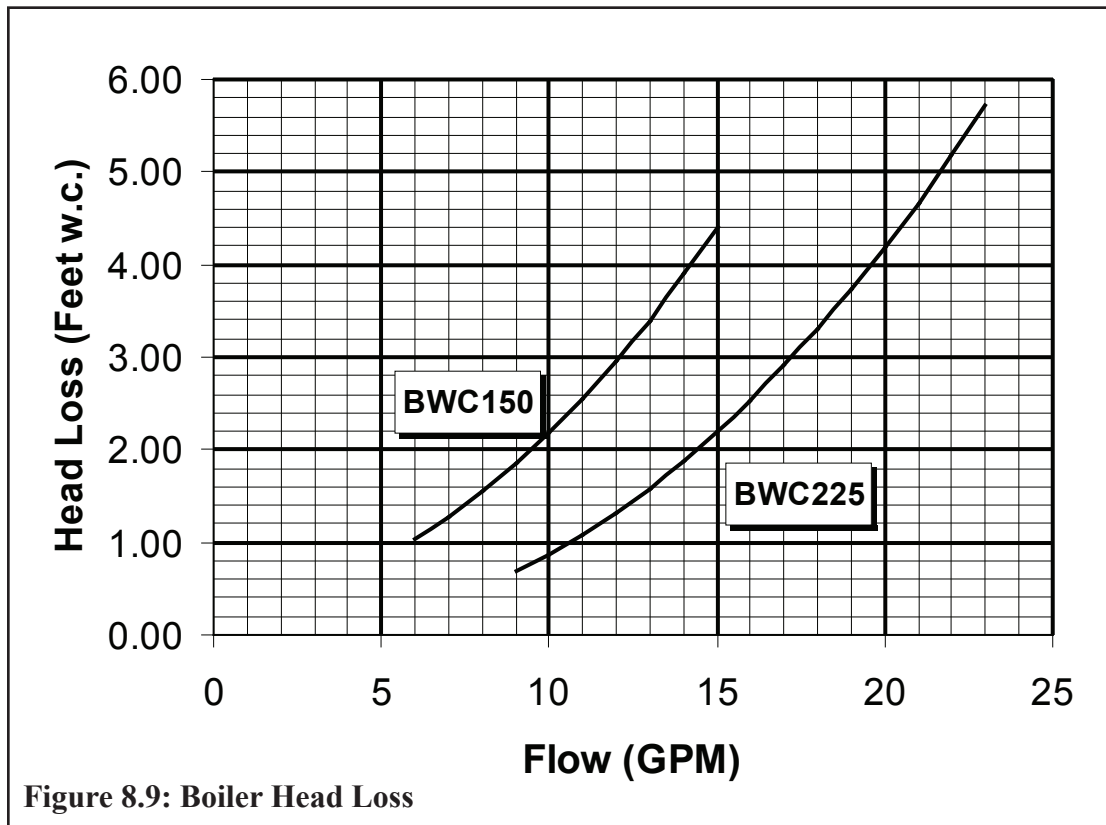

C: Standard Piping Installation Requirements

Observe the following guidelines when making the actual installation of the boiler piping:

- 1) The relief valve is packaged loose with the boiler and must be installed in the location shown in Figure 2.1. The relief valve is set to open at 30 psi. If the valve is replaced, the replacement must have a relief capacity in excess of the DOE heating capacity for the boiler. Pipe the discharge of the relief valve to a location where water or steam will not create a hazard or cause property damage if the valve opens. The end of the discharge pipe must terminate in an unthreaded pipe. If the relief valve discharge is not piped to a drain, it must terminate at least 6 inches above the floor. Do not run relief valve discharge piping through an area that is prone to freezing. The termination of the relief valve discharge piping must be in an area where it is not likely to become plugged by debris.
- 2) The fitting in which the gauge, relief valve and LWCO are to be mounted must not be moved from the factory specified location (Figure 2.1).

DANGER

- PIPE RELIEF VALVE DISCHARGE TO A SAFE LOCATION.
- DO NOT INSTALL A VALVE IN THE RELIEF VALVE DISCHARGE LINE.
- DO NOT INSTALL RELIEF VALVE IN A LOCATION OTHER THAN THAT SPECIFIED BY THE FACTORY.
- DO NOT PLUG THE RELIEF VALVE DISCHARGE.

- 3) The return piping may be connected into the boiler through the back or sides of the boiler by rotating the drain elbow and routing the return piping through the appropriate knockout.
- 4) Circulator (Required) - Usually at least two circulators will be required to properly install a BWC Series boiler. See previous section (System Design) for information on sizing the circulators.
- 5) Expansion Tank (Required) - If this boiler is replacing an existing boiler with no other changes in the system, the old expansion tank can generally be reused. If the expansion tank must be replaced, consult the expansion tank manufacturer's literature for proper sizing.
- 6) Fill Valve (Required) - Either a manual or automatic fill valve may be used. The ideal location for the fill is at the expansion tank.
- 7) Automatic Air Vent (Required) - At least one automatic air vent is required. Manual vents will usually be required in other parts of the system to remove air during initial fill.
- 8) Manual Reset High Limit (Required by some codes) - This control is required by ASME CSD-1 and some other codes. Install the high limit in the boiler supply piping just above the boiler with no intervening valves. Set the manual reset high limit to 200°F. Wire the limit per Figures 9.1 & 9.2 in the Wiring section.
- 9) Flow Control Valve (Required) - The flow control valve prevents flow through the system unless the circulator is operating. Flow control valves are used to prevent gravity circulation or "ghost flows" in circulator zone systems through zones that are not calling for heat.
- 10) Isolation Valves (Recommended) - Isolation valves are useful when the boiler must be drained, as they will eliminate having to drain and refill the entire system.
- 11) Drain Valve (Required) - The drain valve is installed on the return tee located in the lower vestibule compartment as shown in Figure 8.2.
- 12) Low Water Cut-off (Required) - The low water cut-off supplied with this boiler must not be removed.

D. Piping for Special Situations

- 1) Systems containing oxygen - Many hydronic systems contain enough dissolved oxygen to cause severe corrosion damage to an aluminum boiler such as the BWC. Some examples include:

- Radiant systems that employ tubing without an oxygen barrier.
- Systems with routine additions of fresh water.
- Systems which are open to the atmosphere.

If the boiler is to be used in such a system, it must be separated from the oxygenated water being heated with a heat exchanger as shown in Figure 8.10. Consult the heat exchanger manufacturer for proper heat exchanger sizing as well as flow and temperature requirements. All components on the oxygenated side of the heat exchanger, such as the pump and expansion tank, must be designed for use in oxygenated water.

- 2) Piping with a Chiller - If the boiler is used in conjunction with a chiller, pipe the boiler and chiller in parallel as shown in Figure 8.11. Use isolation valves to prevent chilled water from entering the boiler.
- 3) Air Handlers - Where the boiler is connected to air handlers through which refrigerated air passes, use flow control valves in the boiler piping or other automatic means to prevent gravity circulation during the cooling cycle.

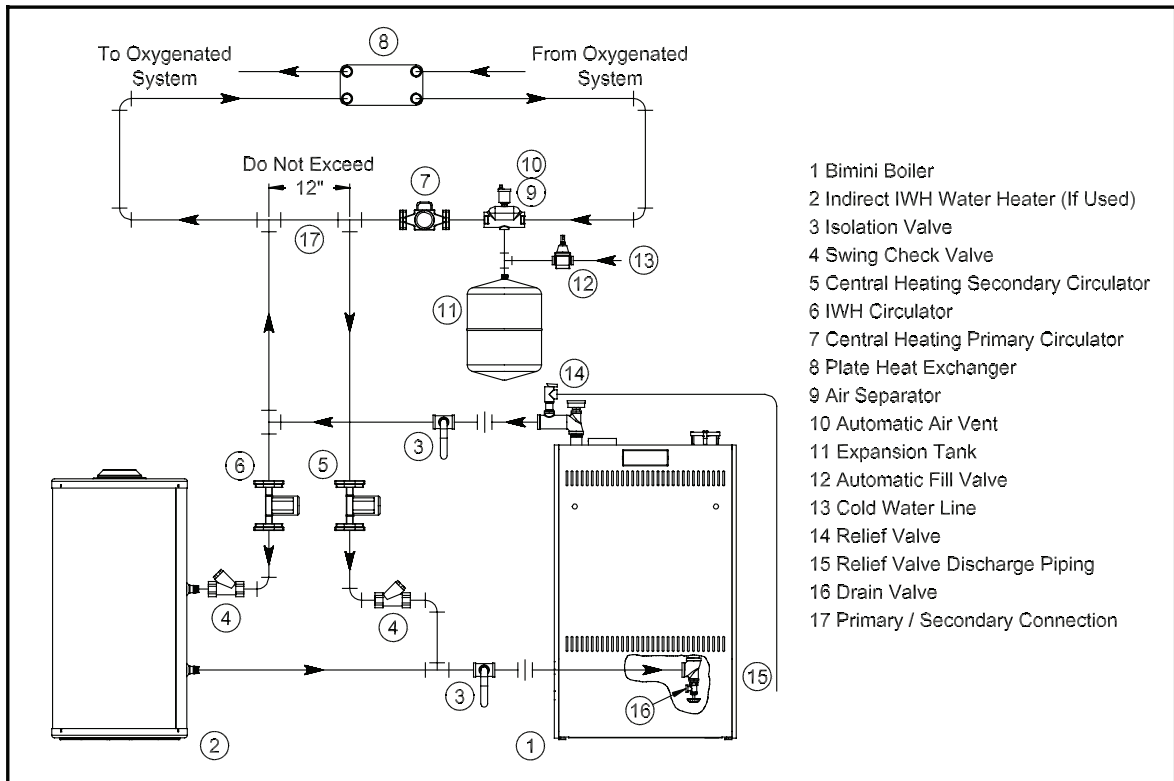

Figure 8.10: Isolation of the Boiler From Oxygenated Water with A Plate Heat Exchanger

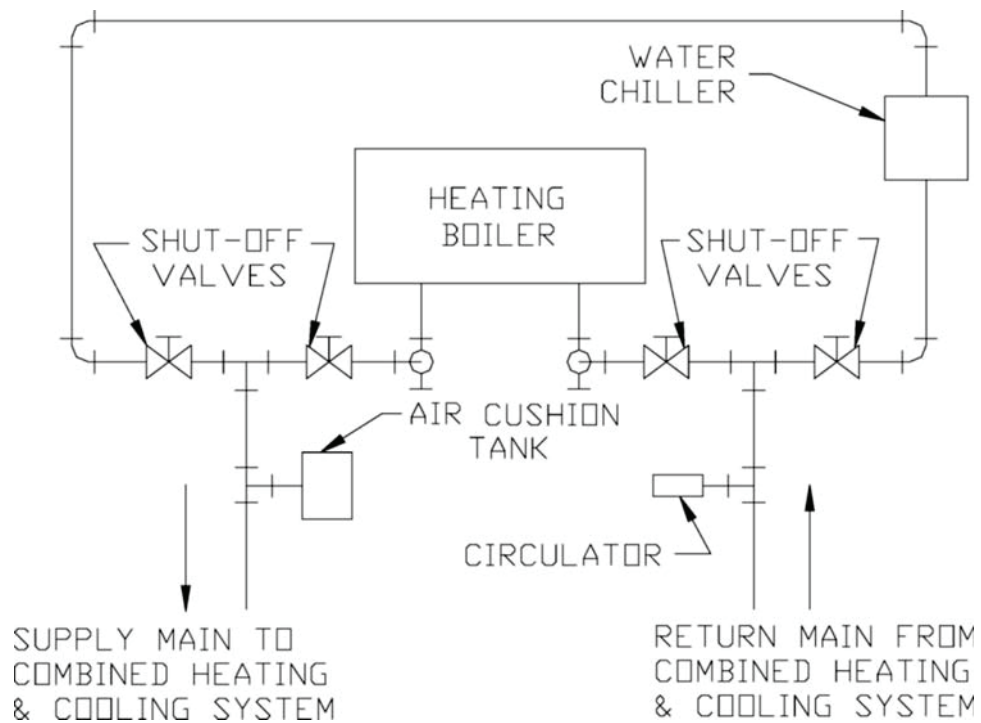

Figure 8.11: Chiller Piping

IX Wiring

WARNING

All wiring and grounding must be done in accordance with the authority having jurisdiction or, in the absence of such requirements, with the *National Electrical Code* (ANSI/NFPA 70).

- 1) Line Voltage (120 VAC) Connections (Fig 9.1) – The line voltage connections are located in the junction box on the right side of the vestibule:
 - Black – Line voltage “hot”
 - White – “Neutral” for boiler and circulators
 - Red – “Heating” circulator “hot”
 - Blue – “Indirect Water Heater “ circulator “hot”
 - Green – Ground connection
- 2) Maximum circulator continuous current draw is 2A. When Piping Method #1 is used, it may be desirable to use the boiler to directly control the primary circulator in addition to the secondary circulator. If this is done, control both heating circulators using a relay with a 120VAC coil, such as a Honeywell R4222, as shown in Figure 9.3. Select a relay with a contact rating in excess of the combined draw of the two circulators.
- 3) Low Voltage Connections (Fig 9.1) – These connections are screw terminals located on the terminal strip next to the junction box on the left:
 - Terminals 1 and 2 – “Heating” thermostat connections
 - Terminals 3 and 4 – “External Limit Control” connections
 - Terminals 5 and 6 – “Outdoor Reset Sensor” connections
 - Terminals 7 and 8 – “Domestic Indirect Water Heater” thermostat connections
 - Terminal 9 – “Flame Signal Reading”
 - Heat anticipator setting for the thermostat connection is 0.1 A when thermostat is connected directly to terminals 1 and 2.

CAUTION

- WHEN MAKING LOW VOLTAGE CONNECTIONS, MAKE SURE THAT NO EXTERNAL POWER SOURCE IS PRESENT IN THE THERMOSTAT OR LIMIT CIRCUITS. IF SUCH A POWER SOURCE IS PRESENT, IT COULD DESTROY THE BOILER’S MICROPROCESSOR CONTROL (MCBA). ONE EXAMPLE OF AN EXTERNAL POWER SOURCE THAT COULD BE INADVERTENTLY CONNECTED TO THE LOW VOLTAGE CONNECTIONS IS A TRANSFORMER IN OLD THERMOSTAT WIRING.

- 4) If the outdoor sensor is connected to terminals 5 and 6, the boiler will adjust the target space heating set point supply water temperature downwards as the outdoor air temperature increases. If used, this sensor should be located on the outside of the structure in an area where it will sense the average air temperature around the house. Avoid placing this sensor in areas where it may be covered with ice or snow. In general, locations where the sensor will pick up direct radiation from the sun should also be avoided. Avoid placing the sensor near potential sources of electrical noise such as transformers, power lines, and fluorescent lighting. Wire the sensor to the boiler using 22 gauge or larger wire. As with the sensor, the sensor wiring should be routed away from sources of electrical noise. Where it is impossible to avoid such noise sources, wire the sensor using a 2 conductor, UL Type CM, AWM Style 2092, 300Volt 60°C shielded cable. Connect one end of the shielding on this cable to ground.

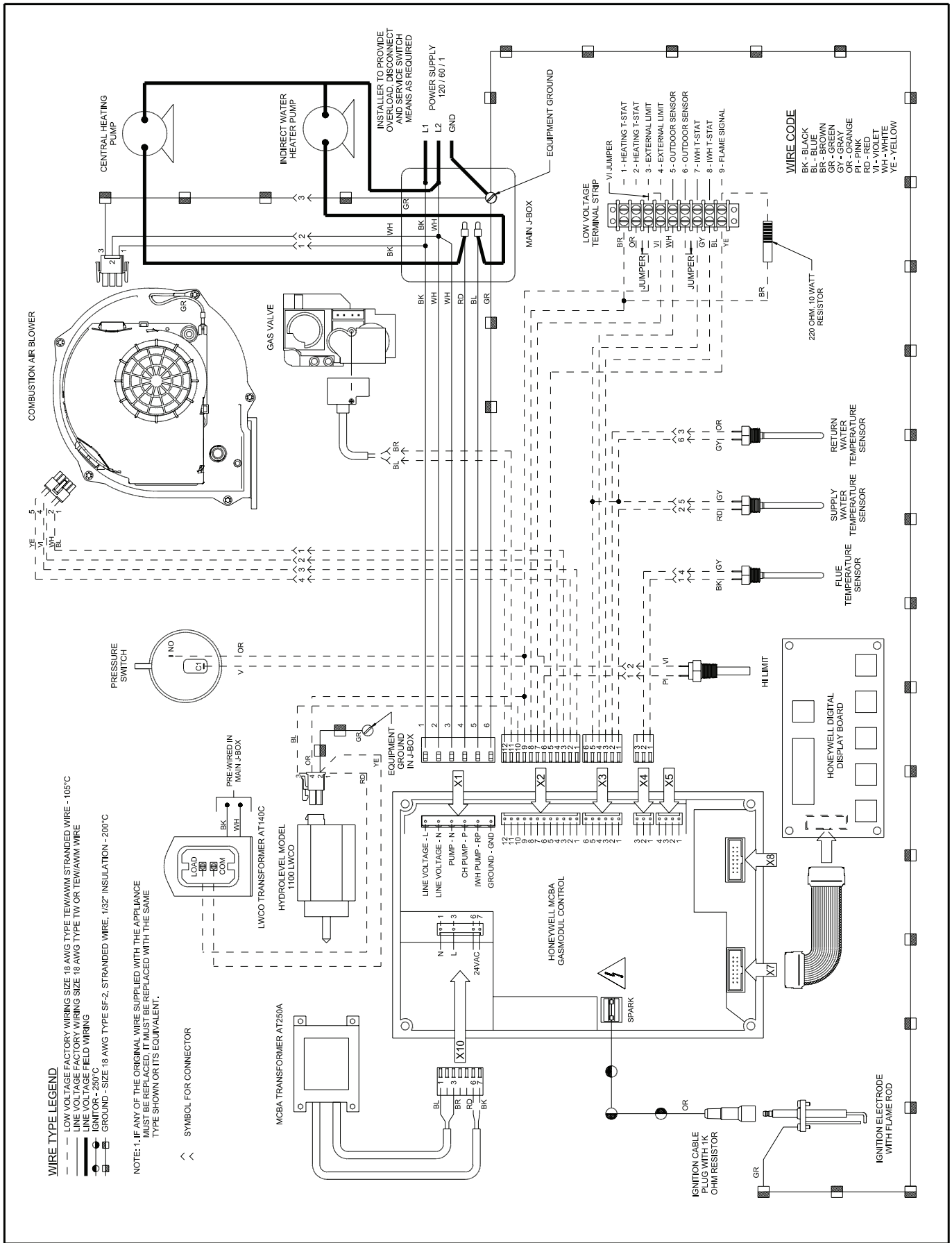

Figure 9.1: Wiring Connections Diagram

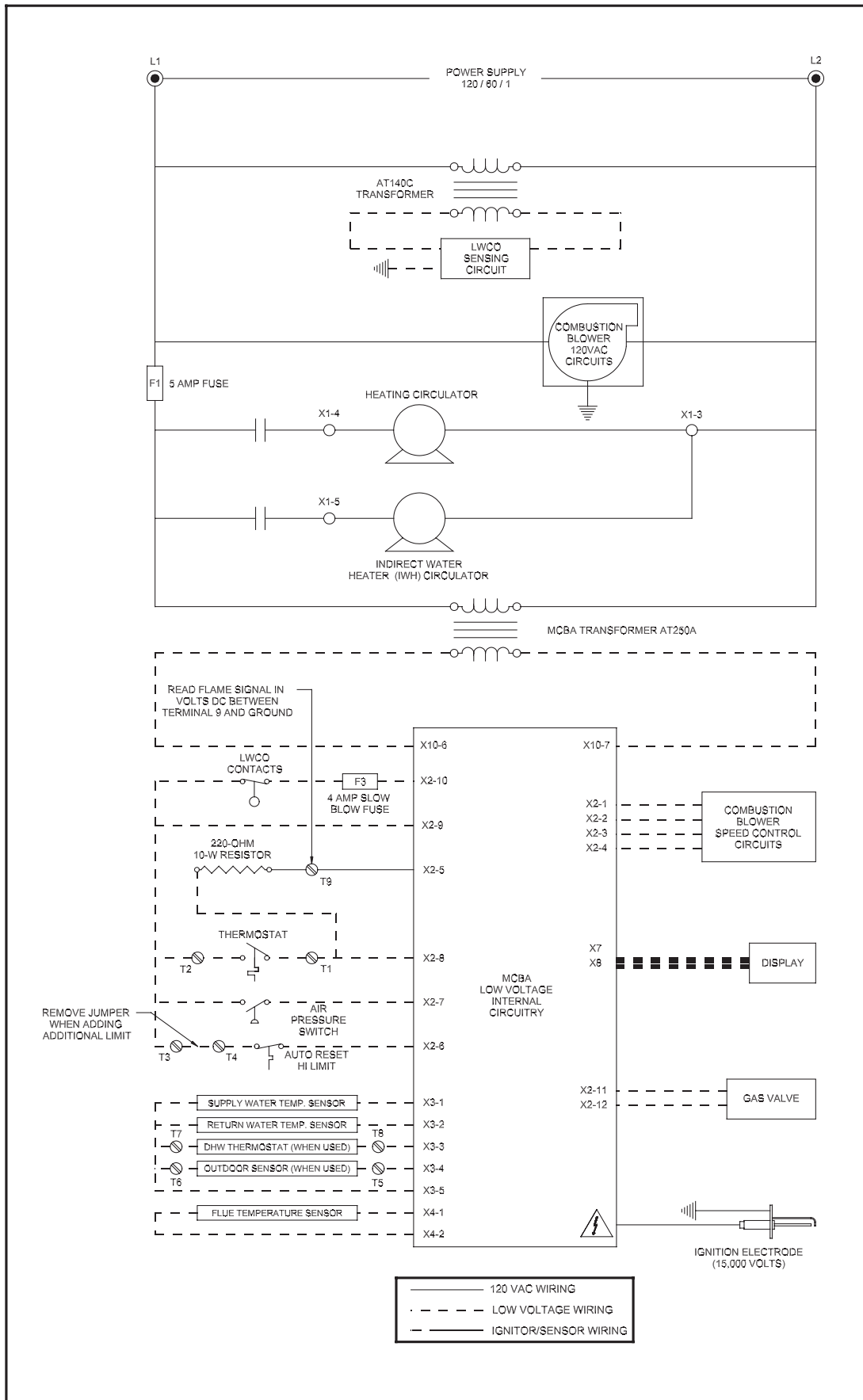

Figure 9.2: Ladder Diagram

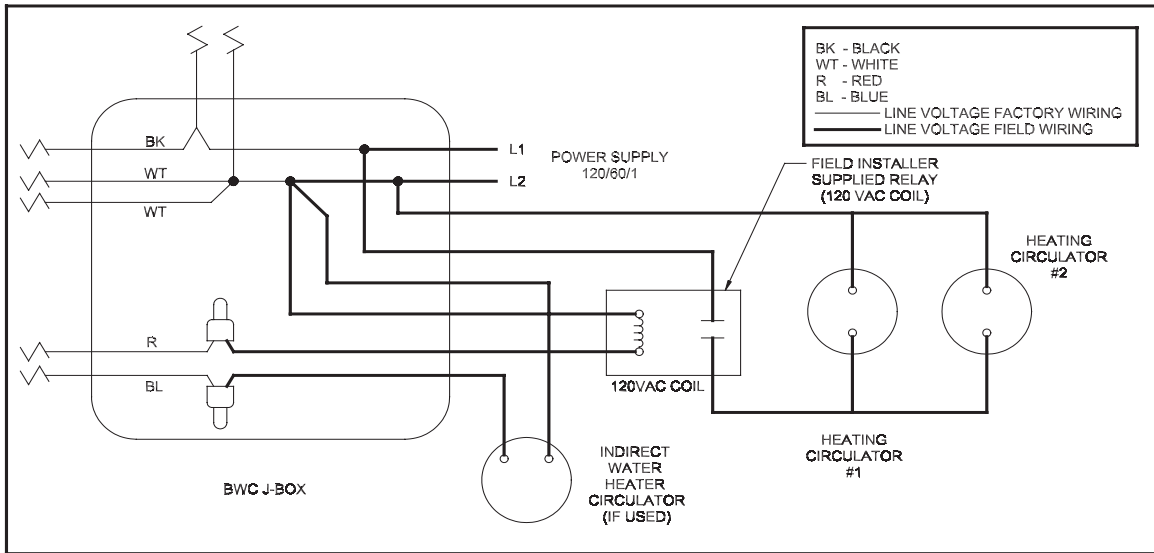

Figure 9.3: Wiring of Isolation Relay for Control of Two Heating Circulators

X Start-up and Checkout

NOTE

SAFE LIGHTING AND OTHER PERFORMANCE CRITERIA WERE MET WITH THE GAS TRAIN ASSEMBLY PROVIDED ON THE BOILER WHEN THE BOILER UNDERWENT THE TEST SPECIFIED IN Z21.13.

Use the following procedure for initial start-up of the boiler:

- 1) If not already done, flush the system to remove sediment, flux, and traces of boiler additives. This should be done with the boiler isolated from the system.
- 2) Fill the boiler and hydronic system with water meeting the following requirements:
 - pH between 6.5 and 8.5
 - Total Solids less than 2500 PPM
 - Hardness less than 120 PPM (7 Grains/Gallon)
 - Pressurize the system to at least 12 psi at the boiler

WARNING

- NEVER ATTEMPT TO FILL A HOT EMPTY BOILER.

- 3) Check all new piping for leaks and purge piping sections that are filled with air. See the *National Fuel Gas Code* for additional information on testing and purging gas lines.

WARNING

- NEVER USE A FLAME TO CHECK FOR GAS LEAKS.
- MAKE SURE THAT THE AREA AROUND THE BOILER IS CLEAR AND FREE FROM COMBUSTIBLE MATERIALS, GASOLINE AND OTHER FLAMMABLE VAPORS AND LIQUIDS

- 4) Vent system must be complete and free of obstructions before attempting to fire boiler. Make sure that the silicone cure time called for in the vent assembly instructions has passed before firing boiler.
- 5) Inspect all line voltage wiring for loose or uninsulated connections.
- 6) Remove the dust cap from the condensate trap (Fig 6.11). Add water to the trap until water runs out the condensate drain. Reinstall the dust cap.

WATER QUALITY AND BOILER WATER ADDITIVES IMPORTANT NOTE

This boiler is equipped with an aluminum heat exchanger that can be seriously damaged by failure to follow the following guidelines:

1) Flush the system before connecting the boiler - In a replacement installation, flushing the system will remove sediment, solder flux, and traces of old boiler additives. Even if the system is new, do not omit this step - new systems will contain solder flux and may even contain sediment.

2) Make sure that the system is tight - **This is the single most important guideline.** Tap water contains dissolved oxygen which causes corrosion. In a tight system, this oxygen comes out of solution and is quickly removed from the system through the automatic air vent. The system then remains essentially free of oxygen. If the system is not tight, however, frequent additions of make-up water can expose the heat exchanger to oxygen on a continuous basis. In addition, frequent additions of hard make-up water can cause calcium deposits to collect in the heat exchanger, causing severe damage.

To minimize additions of make-up water:

- Inspect the system thoroughly for leaks before placing it in service.
- If the system includes underground piping, or other piping in which a leak might go undetected, consider isolating the boiler from the system with a heat exchanger. Alternatively, consider installing a water meter in the fill line to record additions of make-up water.
- Make sure that the expansion tank is properly sized and in good condition. If it is not, the relief valve may open frequently, resulting in regular additions of make-up water.

3) Radiant Tubing and Oxygen Barriers - Even if the system is tight, oxygen can be introduced into the system through some types of non-metallic tubing used in radiant or snow melt systems. Other non-metallic tubing is equipped with an oxygen barrier to prevent migration of oxygen into the water. If the boiler is to be installed in a system containing non-metallic tubing without an oxygen barrier, it must be isolated from the boiler with a heat exchanger as shown in Figure 9.10.

4) Antifreeze - Do not use antifreeze unless absolutely necessary. If antifreeze must be used, the only permitted antifreezes are:

- Fernox Alphi-11
- Fernox CHP in USP Grade virgin propylene glycol (available from Crown)
- RhoGard Aluminum Safe Multi-Metal Antifreeze

If either of the above antifreezes are used, test the boiler water on an annual basis to ensure that the antifreeze remains non-corrosive. This is done with Fernox test kit I-TK (available from Crown).

5) Other Antifreezes and Boiler Additives - Do not add other additives unless they are specifically approved in writing by Crown for use with this boiler. This includes other “aluminum safe” antifreezes.

6) System PH - Maintain the PH in the system between 6.5 and 8.5.

FOR YOUR SAFETY READ BEFORE LIGHTING

WARNING: If you do not follow these instructions exactly, a fire or explosion may result causing property damage, personal injury or loss of life.

- A. This appliance does not have a pilot. It is equipped with an ignition device which automatically lights the burner. Do not try to light the burner by hand.
- B. BEFORE OPERATING smell all around the appliance area for gas. Be sure to smell next to the floor because some gas is heavier than air and will settle on the floor.

WHAT TO DO IF YOU SMELL GAS

- Do not try to light any appliance.
- Do not touch any electric switch; do not use any phone in your building.
- Immediately call your gas supplier from a neighbor's phone. Follow the gas supplier's instructions.

- If you cannot reach your gas supplier, call the fire department.

- C. Use only your hand to turn the gas control knob. Never use tools. If the knob will not push in or turn by hand, don't try to repair it, call a qualified service technician. Force or attempted repair may result in a fire or explosion.
- D. Do not use this appliance if any part has been under water. Immediately call a qualified service technician to inspect the appliance and to replace any part of the control system and any gas control which has been under water.

OPERATING INSTRUCTIONS

1. STOP! Read the safety information above on this label.
2. Set the thermostat to the lowest setting.
3. Turn off all electric power to the appliance.
4. This appliance is equipped with an ignition device which automatically lights the burner. Do not try to light the burner by hand.
5. Remove the front door panel and the upper boiler access panel.

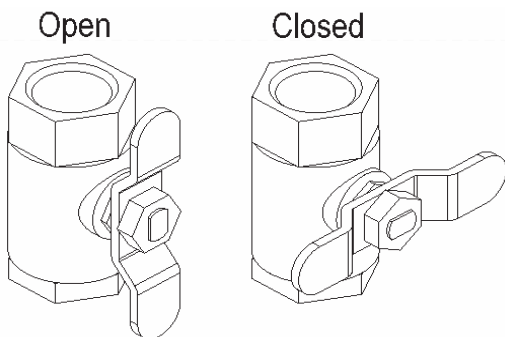

External Boiler Manual Gas Valve

6. Turn the external boiler manual gas valve T-handle counterclockwise to open gas supply. 
7. Smell for gas in the boiler enclosure. If you smell gas, STOP! Follow "B" in the safety information above. If you don't smell gas, go to the next step.
8. Turn on all electric power to the appliance.
9. Set the thermostat to the desired setting.
10. The first digit of the control display panel will show a series of numbers that indicate the boiler control sequence. The number 3 or 4 means the burner is firing. The number 0 means there is no call for heat from the thermostat or the domestic water heater.
11. If the appliance will not operate, follow the instructions "To Turn Off Gas To Appliance" below and call your service technician or gas supplier.
12. Replace the upper boiler access panel and the front door panel.

TO TURN OFF GAS TO THE APPLIANCE

1. Turn off all electric power to the appliance if service is to be performed.
2. Set the thermostat to the lowest setting.
3. Turn the external boiler manual gas valve T-handle clockwise to close the gas supply. 
4. Replace the upper boiler access panel and the front door panel.

- 7) Start the boiler using the lighting instructions on page 39. After the boiler is powered up, it should go through the following sequence.

Sequence	Display	Meaning
1	<i>U.125</i> or Blank	Checking internal software (power-up only)
2	<i>0.5WT</i>	Boiler in standby. <i>5WT</i> = Supply Water Temp. No call for heat. (After call for heat from heating thermostat)
3	<i>R.5WT</i>	Self-Check on Start-up
4	<i>5.5WT</i>	Blower and circulator on. Checking for adequate air flow.
5	<i>1.5WT</i>	Prepurge
6	<i>2.5WT</i>	Trial for ignition
7	<i>3.5WT</i>	Flame established. Boiler responding to a call for heat.

- 8) Upon initial start-up, the gas train will be filled with air. Even if the gas line has been completely purged of air, it may take several tries for ignition before a flame is established. If more than 5 tries for ignition are needed, it will be necessary to press the reset button to restart the boiler. Once a flame has been established for the first time, subsequent calls for burner operation should result in a flame on the first try.
- 9) Inspect the flame visible through the window. On high fire the flame should be stable and mostly blue (Fig.10.1). No yellow tipping should be present; however, intermittent flecks of yellow and orange in the flame are normal.

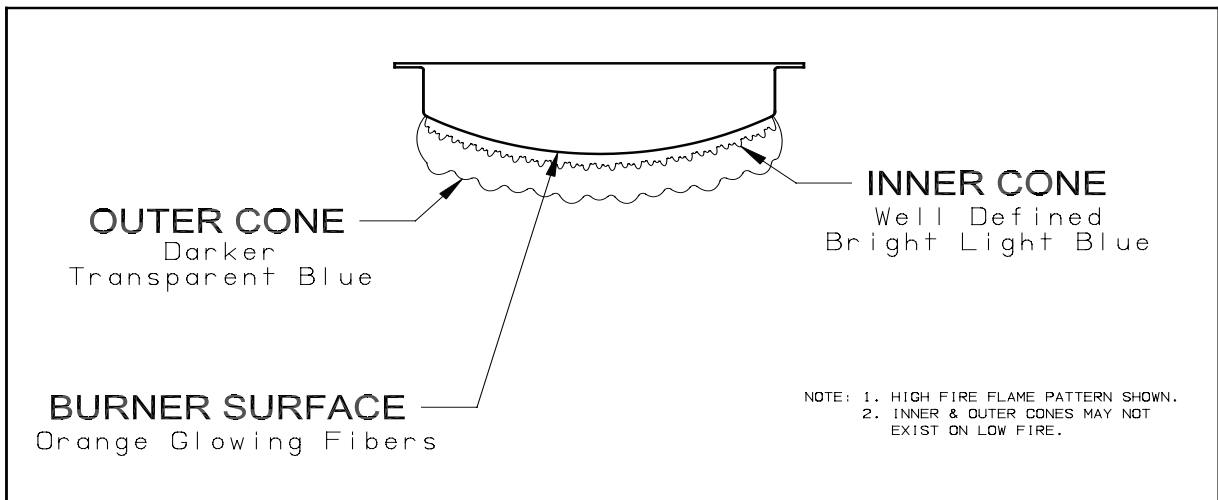
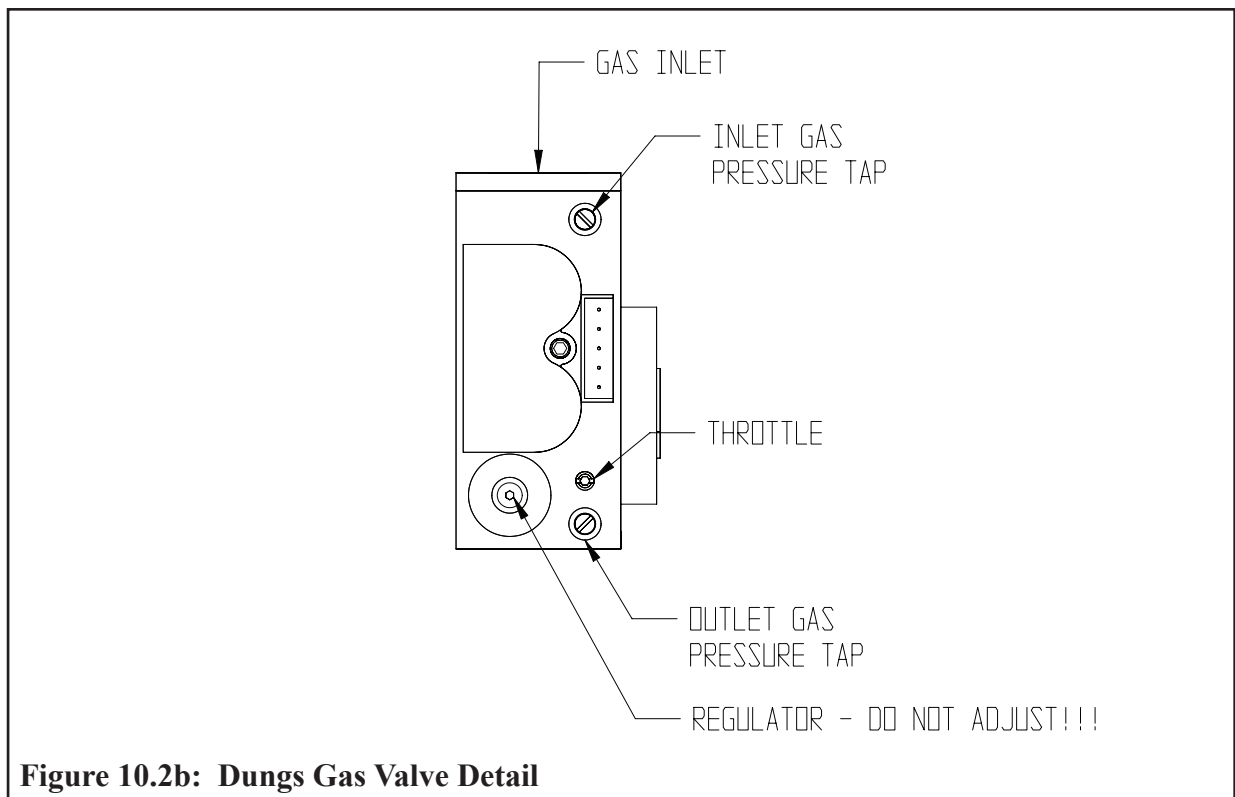
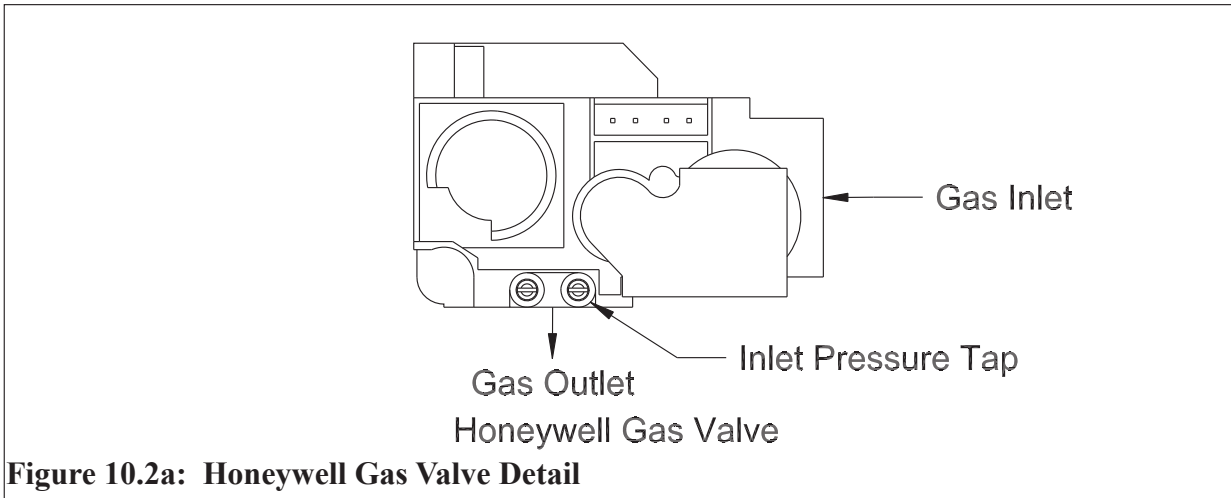

Figure 10.1: BWC Burner

- 10) Check the inlet pressure and adjust if necessary. Verify that the inlet pressure is between the upper and lower limits shown on the rating plate with all gas appliances on and off.

WARNING

THE CORRECT OUTLET PRESSURE FOR THE GAS VALVE HAS BEEN FACTORY SET AND REQUIRES NO FIELD ADJUSTMENT. THIS SETTING IS SATISFACTORY FOR BOTH NATURAL GAS AND PROPANE. ATTEMPTING TO ADJUST THE OUTLET PRESSURE MAY RESULT IN DAMAGE TO THE GAS VALVE AND CAUSE PROPERTY DAMAGE, PERSONAL INJURY OR LOSS OF LIFE.



- 11) Perform a combustion test. On horizontally vented units, the sample probe may be inserted into the terminal. If this is not possible, and if no sample tap is present in the vent system, remove the flue temperature sensor and insert the analyzer probe in the sensor opening. On the BWC150 and BWC225 the flue temperature probe is located behind the lower vestibule door. For the boiler to operate, this sensor will need to be temporarily connected outside of the boiler. If it is removed, be sure to return the flue gas temperature sensor to its original position after combustion testing is complete. Check CO₂ (or O₂) and CO at both high and low fire. The boiler may be temporarily locked into high or low fire for 15 minutes as follows:
- a) To lock the boiler in high fire, simultaneously press and hold the “Mode” button and “+“ button until the display flashes “H”, indicating that the boiler has been driven to high fire. After this happens, allow the boiler to operate for approximately 5 minutes before taking combustion readings.

b) To lock the boiler in low fire, simultaneously press and hold the “Mode” button and “-“ button until the display flashes “L”, indicating that the boiler has been driven to low fire. After this happens, allow the boiler to operate for approximately 5 minutes before taking combustion readings.

At both high and low fire, CO readings should be less than 75 PPM. Typical CO2 readings are shown in Table 10.3. Normal modulation should return 15 minutes after the boiler is locked in high or low fire.

12) Test any external limits or other controls in accordance with the manufacturer’s instructions.

13) Verify that the boiler starts and stops in response to calls for heat from the heating thermostat and indirect water heater thermostat. Make sure that the appropriate circulators also start and stop in response to the thermostats.

Table 10.3: Typical Sea Level CO2/O2 Combustion

Model	Fuel	%CO2	%O2
BWC150 (Honeywell Valve)	Natural Gas	8.2	6.3
BWC150 (Dungs Valve)	Natural Gas	8.7	5.6
BWC225 (Honeywell Valve)	Natural Gas	9.0	5.1
BWC150 (Honeywell Valve)	Propane	NA	NA
BWC150 (Dungs Valve)	Propane	10.1	5.6
BWC225 (Honeywell Valve)	Propane	10.2	5.4

WARNING

EACH BWC SERIES BOILER IS TESTED AT THE FACTORY AND ADJUSTMENTS TO THE AIR-FUEL MIXTURE ARE NORMALLY NOT NECESSARY. CONSULT A CROWN REPRESENTATIVE BEFORE ATTEMPTING TO MAKE ANY SUCH ADJUSTMENTS. IMPROPER GAS VALVE OR MIXTURE ADJUSTMENTS COULD RESULT IN PROPERTY DAMAGE, PERSONAL INJURY, OR LOSS OF LIFE.

XI Operation

- 1) The BWC boiler uses a microprocessor based control, known as a “MCBA”, to manage all boiler functions including flame supervision and modulation. Two set point or “target” boiler supply temperatures are stored in the MCBA’s memory; one for space heating and one for domestic water production. If an outdoor temperature sensor is connected to the boiler, the space heating supply set point will automatically adjust downwards as the outdoor temperature increases. For more information on this feature see the discussion on boiler water reset below.

The MCBA modulates the boiler input by varying the fan speed. As the fan speed increases, so does the amount of gas drawn into the blower. As a result, a fairly constant air-fuel ratio is maintained across all inputs.

The MCBA determines the input needed by looking at both current and recent differences between the supply temperature and the set point temperature. As the supply temperature approaches the set point temperature, the fan will slow down and the input drop. Depending on the model boiler, the minimum input is between ¼ and 1/5 of maximum input.

The MCBA also monitors boiler return and flue temperatures. In addition, all other safety controls, including the low water cut-off and safety limit, are connected into the MCBA. The MCBA uses input from all of these controls to either shut down the boiler when an unsafe condition exists or, in some cases, to correct the problem.

- 2) The display panel has three primary modes of operation. These are:
 - Standby Mode – Displays boiler’s current status. This is the default operating mode.
 - Parameter Mode – Used to change control settings
 - Information Mode – Displays boiler operating temperatures

Under normal conditions, the boiler is in standby mode and the display looks like that shown in Figure 11.1. The three digits to the right of the decimal point are the boiler’s supply temperature. The digit to the left of the decimal point is the boiler’s status code. A list of status codes, and their meanings, is shown in Table 11.3. Figure 11.2 is a map of the menu structure for the control panel. Push the mode key to move from one mode to the next. As you change modes, the mode you are entering is shown on the display:

- a) “*PARP*” for Parameter Mode
- b) “*Info*” for Information Mode
- c) “*Stby*” for Standby Mode. Upon entering standby mode, “Stby” will briefly appear on the display and then the display will show the boiler’s status along with the supply temperature (Figure 11.1).

The control will return to standby mode from any other mode if no key is pressed for 20 minutes.

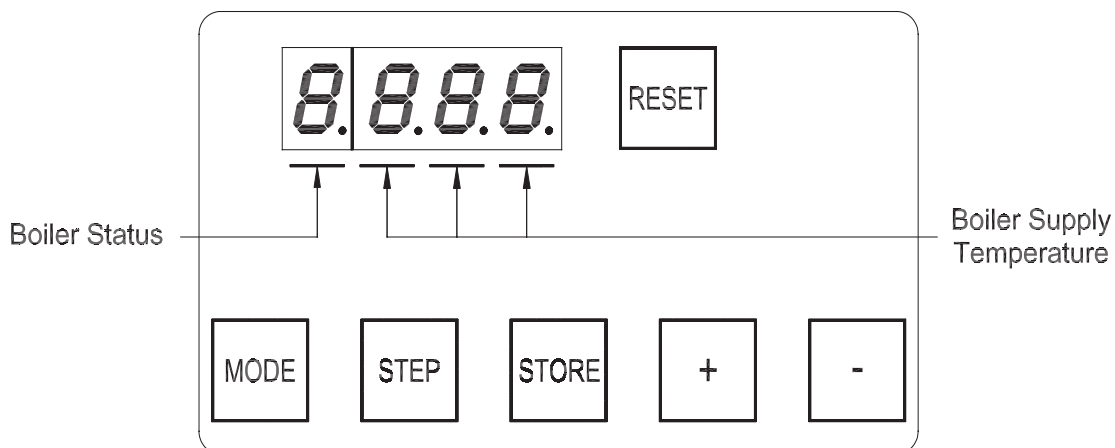

Figure 11.1: Normal Display In Standby Mode

In standby mode, it is possible to view both the heating supply set point temperature and the “domestic hot water reference set point”. The “domestic hot water reference set point” plus 45°F equals the boiler supply set point when it is responding to a call from the indirect water zone. It is not the actual domestic hot water set point. The BWC is designed for use with a storage type indirect water heater such as the Crown Mega-Stor. The domestic water set point is controlled by the thermostat on the indirect water heater. The “default domestic water reference set point” is 135°F and target boiler supply temperature when responding to a call from the indirect water heater is therefore 180°F (135°F +45°F). The default heating supply set point (parameter 4) is 180°F.

In standby mode it is also possible to turn on or off either the heating or domestic water zone. There is normally no reason to turn off either of these zones and doing so is not recommended.

CAUTION

PUSHING AND HOLDING THE “+” WHILE IN STANDBY MODE WILL PREVENT THE BOILER FROM RESPONDING TO A CALL FOR HEAT. PUSHING AND HOLDING THE “-” WHILE IN STANDBY MODE WILL PREVENT THE BOILER FROM RESPONDING TO A CALL FOR DOMESTIC WATER. IF THIS HAPPENS, “cOFF” or “dOFF” WILL APPEAR ON THE DISPLAY. TO TURN BACK ON THE HEATING FUNCTION, PRESS AND HOLD “+” UNTIL “c” AND THE SET POINT TEMPERATURE APPEARS ON THE DISPLAY. TO TURN BACK ON THE DOMESTIC WATER FUNCTION, PRESS AND HOLD “-” UNTIL “d” AND THE SET POINT TEMPERATURE APPEARS ON THE DISPLAY. AFTER PRESSING ANY KEYS, AND BEFORE LEAVING THE INSTALLATION, VERIFY THAT THE BOILER FIRES IN RESPONSE TO A CALL FOR HEAT AND DOMESTIC WATER.

In standby mode, if “Mode” and either “+” or “-“ are simultaneously pushed and held for at least 2 seconds, the burner can be forced into either high or low fire. This feature is used for running combustion tests. After 15 minutes, the burner will automatically revert to modulation. If it is desired to revert to modulation before 15 minutes has passed, simultaneously pushing “+” and “-“ will restore modulation.

In Parameter mode both set points can be changed and both zones turned on or off. In addition, both zones can be configured for continuous pump operation. If the heating zone is set for continuous pump operation (parameter 3 set to 3), the heating pump will still shut down when there is a call for domestic hot water.

If either the heating supply set point (parameter 4) , or the DHW reference set point (parameter 1) are set above their factory set values, the boiler supply temperature will exceed 180°F and there is a possibility that the safety temperature limit will open. If this happens, the boiler will shut down and a “b26” error will appear on the display. The boiler will resume normal operation without manual intervention when the safety limit closes (this behavior is common on conventional boilers).

Information mode is used to view various temperatures and settings but cannot be used to change parameters or otherwise control the boiler. The information available is shown in Figure 11.2 and is largely self-explanatory. The digit to the left of the decimal point is the Step number and the digits to the right are the corresponding temperature.

In information mode, the “supply water temperature set point” (Step 6), is the supply temperature set point for the zone to which the boiler is currently responding (either heat or DHW). If an outdoor sensor is connected to the boiler, and the boiler is responding to a call for heat, this value will be the current point on the reset curve. When no call for heat or DHW is present, Step 6 shows the heating supply set point.

In some cases a “-22” will appear in Information Mode for a particular reading. This means that the reading is not applicable. For example, “-22” will appear for the outdoor temperature (Step 4) if no outdoor sensor is connected to the boiler.

FIGURE 11.2: BASIC MENU TREE

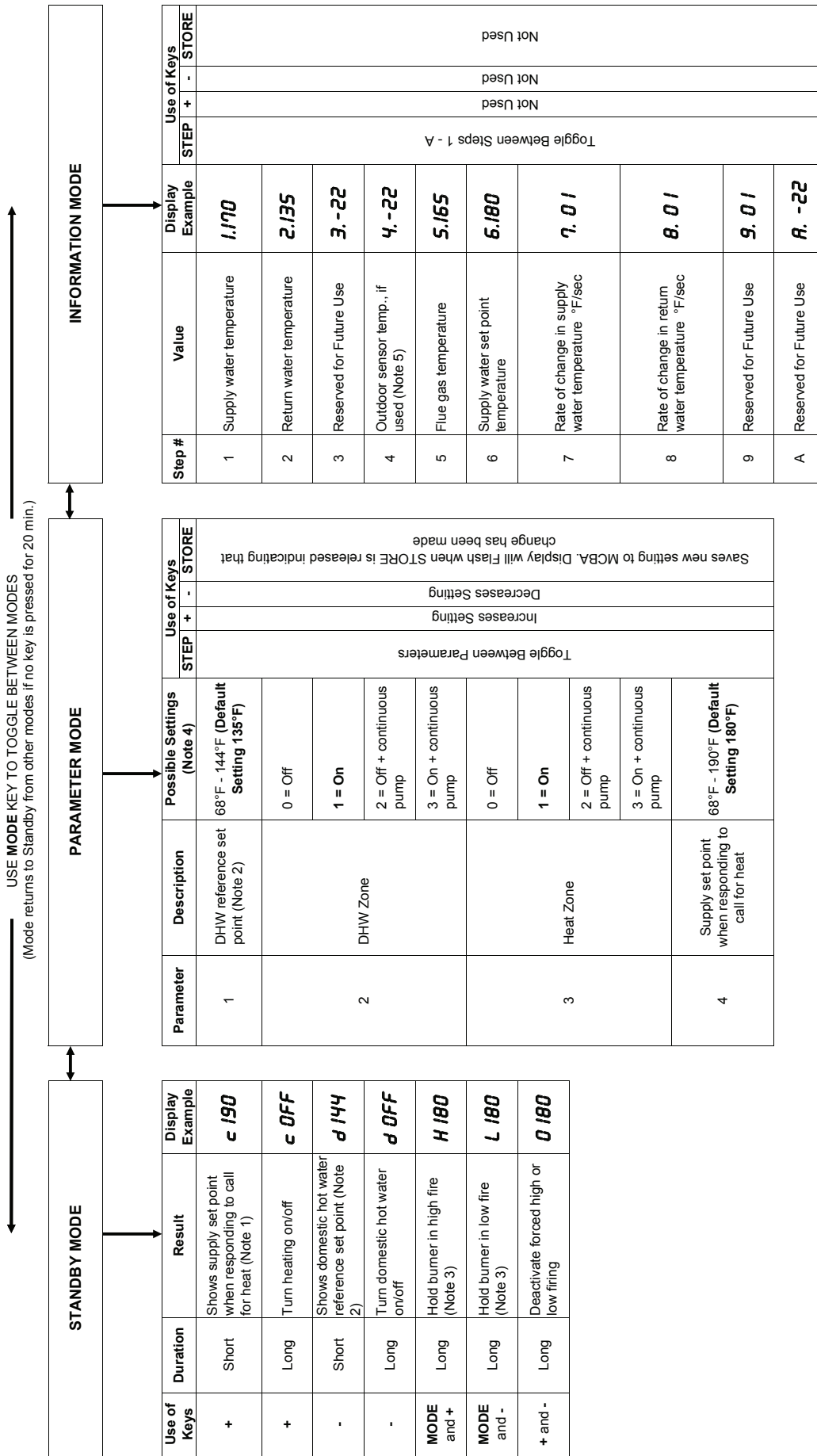

Notes

- 1) If outdoor sensor is connected, this temperature is the supply temperature setpoint when the outdoor temperature is 0°F.
- 2) "Domestic water reference set point" + 45°F = boiler supply set point when boiler is responding to a call for domestic hot water (default = 180°F).
- 3) Boiler will automatically resume modulation after 15 minutes.
- 4) Factory default settings are shown in bold.
- 5) If no outdoor sensor is connected, display reads "4.-22".

3) Two basic types of errors codes are shown on the display:

- Soft Lockout Codes – When a soft lockout occurs, the boiler will shut down and the display will alternate between the number “9” and the letter “b” followed by a two digit service code. A list of these codes, and their meanings, is shown in Table 13.3. The boiler will automatically restart once the condition that caused the lockout is corrected.
- Hard Lockout Codes – When a hard lockout occurs, the boiler will shut down and the display will flash the letter “E” followed by a two digit service code. A list of these codes, and their meanings, is shown in Table 13.4. Once the condition that caused the lockout is corrected, the boiler will need to be manually reset using the RESET button on the display.

First Digit	Boiler Status
0	Burner off - No call for heat or DHW
1	Pre-purge or post-purge
2	Ignition
3	Burner responding to call for heat
4	Burner responding to call for DHW
5	Checking air pressure switch
6	Burner off - Set point temperature has been reached
7	Call for heat ended. 10s heating post pump period
8	Call for DHW ended. 10s DHW post pump period
9 and b Flashing	Burner off - on soft lockout. See Troubleshooting Section to determine meaning of error code.
A	Boiler responding to call from heating zone
H	Burner on - Held in high fire
L	Burner on - Held in low fire

Table 11.3: Boiler Status

- 4) If an outdoor sensor is installed, the boiler will automatically adjust the heating zone set point temperature based on the outdoor reset curve in Figure 11.4. The maximum set point is defined by parameter 4 (factory set to 180°F) when the outdoor temperature is 0°F or below. The minimum set point temperature shown is 130°F when the outdoor temperature is also 60°F or above. As the outdoor temperature falls the supply water target temperature increases. For example, if the outdoor air temperature is 30°F, the set point temperature for the supply water is 155°F.
- 5) An indirect water heater thermostat can be connected between terminals 7 and 8 on the terminal strip. When this thermostat closes, the central heating circulator will be turned off and the DHW circulator will be turned on.
- 6) An external limit control can be installed between terminals 3 and 4 on the terminal strip. Be sure to remove the jumper between terminals 3 and 4 when adding an external limit control to the system. If the external limit opens, the boiler will shut down and error code “b 26” will be displayed. If the limit installed is a manual reset type, it will need to be reset before the boiler will operate.

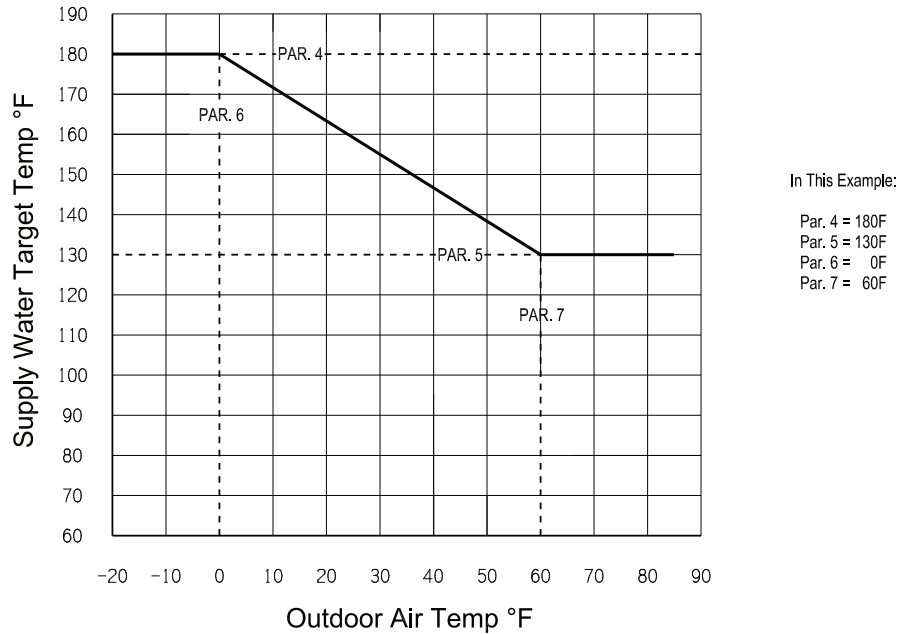

Figure 11.4: Outdoor Reset Curve

- 7) The sequence of operation for a BWC series boiler on a call for heat from a thermostat is as described below:
 - a) When power is first turned on, 120V is provided to the MCBA, the combustion fan and the LWCO transformer. A separate 50VA transformer, connected directly to the MCBA, powers all other low voltage circuits.
 - b) For the first few seconds after power-up the control module goes through a self check.
 - c) When there is a call for heat, the control module checks to make sure the air pressure switch is open. If it is, the combustion fan will be energized and will ramp up to ignition speed. When the air pressure switch closes, a 10 second prepurge is activated.
 - d) After the prepurge, the control module energizes the gas control valve and the spark for 4.5 seconds. If a flame is established and proved, the control allows the flame to stabilize for 5 seconds at the combustion fan ignition speed setting. If the flame fails to prove, the control module will attempt to light the burner 4 more times. If a flame is still not established, the control will lockout.
 - e) Once the flame stabilization period has ended, the MCBA allows the burner to modulate. The actual firing rate is dependent upon the measured current and recent differences between the set point temperature and the supply temperature. If an outdoor sensor is connected to the control module and the boiler is responding to a call for heat, the set point temperature will be determined by the outdoor reset curve shown in Figure 11.4.
 - f) Once the set point temperature is reached, the MCBA will turn the burner off and allow the combustion fan to operate in postpurge for 35 seconds before it turns off.
 - g) The central heating pump will continue to operate until the room thermostat has been satisfied.
 - h) A demand for domestic hot water (DHW) is given priority on BWC series boilers. If a call for DHW is received while the boiler is responding to a call for heat, the heating circulator is deenergized until the call for DHW is satisfied.

XII. Service and Maintenance

IMPORTANT

WARRANTY DOES NOT COVER BOILER DAMAGE OR MALFUNCTION IF THE FOLLOWING STEPS ARE NOT PERFORMED AT THE INTERVALS SPECIFIED

1) Continuously:

- a. Keep the area around the boiler free from combustible materials, gasoline and other flammable vapors and liquids.
- b. Keep the area around the combustion air inlet terminal free from contaminants .
- c. Keep the boiler room ventilation openings open and unobstructed.

2) Monthly Inspections:

- a. Inspect the vent piping and outside air intake piping to verify they are open, unobstructed and free from leakage or deterioration. Call the service technician to make repairs if needed.
- b. Inspect the condensate drain system to verify it is leak tight, open and unobstructed. Call the service technician if the condensate drain system requires maintenance.
- c. Inspect the water and gas lines to verify they are free from leaks. Call the service technician to make repairs if required.

CAUTION

WATER LEAKS CAN CAUSE SEVERE CORROSION DAMAGE TO THE BOILER OR OTHER SYSTEM COMPONENTS. IMMEDIATELY REPAIR ANY LEAKS FOUND.

4) Annual Inspections and Service: In addition to the inspections listed above the following should be performed by a service technician once every year.

- a. Test the low water cutoff by pressing the “Test” button located at its end. The yellow light should come on and “E12” should flash on the display. Push the reset button on the display to restore normal operation. If the yellow light does not come on, determine why the low water cutoff is not working properly.
- b. Follow the procedure for turning the boiler off found in the BWC Series Lighting and Operating Instructions.
- c. Inspect the wiring to verify the conductors are in good condition and attached securely.

CAUTION

LABEL ALL WIRES PRIOR TO DISCONNECTION WHEN SERVICING CONTROLS. WIRING ERRORS CAN CAUSE IMPROPER AND DANGEROUS OPERATION. VERIFY PROPER OPERATION AFTER SERVICING.

- d. Remove the ignition electrode and inspect it for oxides. Clean the oxides off the electrode with sandpaper. Inspect the ceramic insulator for cracks and replace the ignitor assembly as necessary.
 - e. Remove any accumulated debris from the air inlet screen.
 - f. Remove the attenuator hose and clean as necessary. (Note: The nylon cable tie used to hold the attenuator hose in place is releasable.)
 - g. Remove the combustion fan/gas valve assembly and inspect the fan and fan blade for lint and dust. Vacuum as required.
 - h. Remove the burner hood to access the burner and the chamber.
 - i. Remove the burner and vacuum any dust or lint from the burner. Wipe the inside of the burner with a clean soft cloth. Do not wipe the mesh side of the burner. If the burner shows signs of deterioration or corrosion, replace it immediately. Inspect the burner gasket and replace, if necessary.
 - j. With the burner removed, inspect the combustion chamber and clean as necessary.
 - k. Inspect the heat exchanger and vacuum any debris found on the pins and other surfaces. Clean the casting pins by flushing with clean water. A soft nylon brush may be used in accessible areas. Drain and flush the inside of the heat exchanger and condensate collector as required.
 - l. Do not use any cleaning agents or solvents.
 - m. Inspect the condensate trap to verify it is open and free from debris. Clean if necessary.
 - n. Reinstall the burner, burner hood, combustion fan, gas valve assembly and the attenuator hose.
 - o. Reconnect any wiring which has been disconnected.
 - p. Qualified service personnel should thoroughly inspect the heating system and correct any deficiencies prior to restarting the boiler.
 - q. Follow Section X Start-up and Checkout instructions before leaving installation.
 - r. Perform the combustion test outlined in Section X.
 - s. Verify that the system PH is between 6.5 and 8.5

XIII. Troubleshooting

WARNING

TURN OFF POWER TO BOILER BEFORE REPLACING FUSES OR WORKING ON WIRING.

A. Troubleshooting problems where no error code is displayed:

Table 13.1: No Error Code Displayed

CONDITION	POSSIBLE CAUSES
Display Blank, Fan off, LWCO lights off	<ul style="list-style-type: none">• No 120VAC Power at boiler. Check breaker and wiring between breaker panel and boiler
Display Panel Blank, Fan running	<ul style="list-style-type: none">• Loose 120VAC connection wiring between boiler J-Box and MCBA• Blown "F1" fuse in MCBA (see Figure 13.2 for location). Replace with 5A fuse provided
Display reads "U.125" continuously, Fan running	<ul style="list-style-type: none">• Defective AT250 transformer• Blown "F3" fuse in MCBA (see Figure 13.2 for location). Replace with 4A slow-blow fuse provided
Boiler not responding to call for heat, Status code on display = "0" (see Figure 11.1)	<ul style="list-style-type: none">• Boiler is not seeing call for heat. Check thermostat or zone wiring for loose connection, miswiring, or defective thermostat/zone control.
Boiler fires, but display panel is blank	<ul style="list-style-type: none">• Loose ribbon cable• Defective display

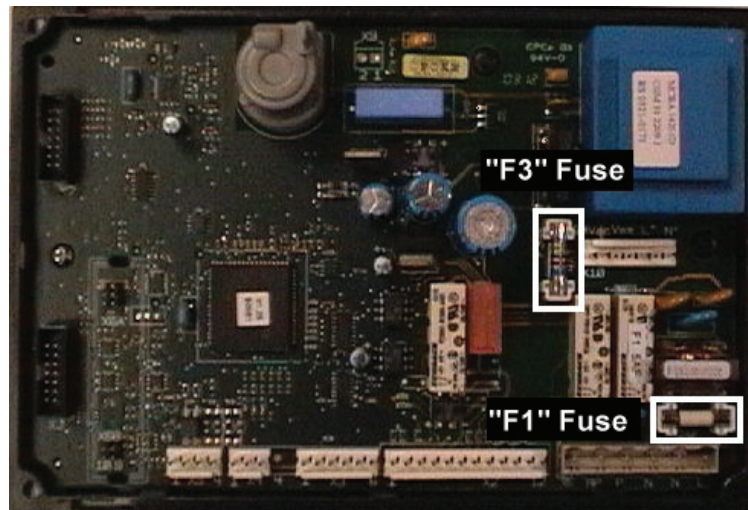

Figure 13.2: MCBA Fuse Location

- B. Trouble shooting problems where a soft lockout code is displayed. When a soft lockout occurs, the boiler will shut down and the display will alternate between the number “9” and the letter “b” followed by a two digit service code. The boiler will automatically restart once the condition that caused the lockout is corrected.

Table 13.3: Soft Lockout Codes Displayed

CODE	CONDITION	POSSIBLE CAUSES
b 08	Pressure switch circuit open	<ul style="list-style-type: none"> • Blockage in intake or vent system. • Vent and/or intake system not constructed in accordance with Part VI. • Blocked or leaking pressure switch tubing • Heat exchanger or burner blockage • Terminals exposed to high winds • Blockage in condensate trap above vent.
b 18	MCBA supply sensor detected temperatures in excess of 200°F	<ul style="list-style-type: none"> • Heating load at time of error was far below the minimum firing rate of the boiler • Defective primary pump or no flow in primary loop (Piping Method 1) • Control system miswired so that boiler operation is permitted when no zones are calling
b 19	MCBA return sensor detected temperatures in excess of 200°F	<ul style="list-style-type: none"> • See possible causes for “b18” • Flow through boiler reversed • Sensor wiring reversed
b 24	MCBA is reading a return sensor temperature higher than the supply sensor temperature. Condition must be present for at least 75s for this error code to appear.	<ul style="list-style-type: none"> • Flow through boiler reversed. Verify correct piping and pump orientation. • No boiler water flow. Verify that system is purged of air and that appropriate valves are open. • Sensor wiring reversed. • Supply or return sensor defective.
b 25	Supply water temperature has risen too quickly	<ul style="list-style-type: none"> • See possible causes for “b18” • Inadequate boiler water flow. Verify that pump is operating and that pump and piping are sized per Part VIII of this manual
b 26	Boiler safety limit, or external limit wired across terminals 3&4, is open.	<ul style="list-style-type: none"> • See possible causes for “b18” • Defective supply sensor.
b 30	Temperature rise between supply and return is too high.	<ul style="list-style-type: none"> • Inadequate boiler water flow. Verify that pump is operating and that pump and piping are sized per Part VIII of this manual
b 61	Pressure switch circuit closed with fan off	<ul style="list-style-type: none"> • Blockage in pressure switch hose • Pressure switch wires shorted together • Defective pressure switch • Loose or miswired fan speed harness (if “b61” error code is observed while fan is running)
b 65	Fan is not achieving set point speed	<ul style="list-style-type: none"> • Loose or incorrect fan speed control connection • Defective fan

- C. Trouble shooting problems where a hard lockout code is displayed. When a hard lockout occurs, the boiler will shut down and the display will flash the letter “E” followed by a two digit service code. Once the condition that caused the lockout is corrected, the boiler will need to be manually reset using the RESET button on the display.

Table 13.4: Hard Lockout Codes Displayed

CODE	CONDITION	POSSIBLE CAUSES
E 00	A flame signal was present when there should be no flame.	<ul style="list-style-type: none"> Defective gas valve - make sure inlet pressure is below maximum on rating plate before replacing valve.
E 02	Flame failure after 5 tries to restart	<ul style="list-style-type: none"> No gas pressure Gas pressure under minimum value shown on rating plate Gas line not completely purged of air Defective Electrode Loose burner ground connection Defective Ignition Cable Defective gas valve (check for 24 VDC at harness during trial for ignition before replacing valve) Air-fuel mixture out of adjustment - consult factory
E 03	Gas valve error	<ul style="list-style-type: none"> Loose or defective gas valve harness. Check electrical connections. Defective gas valve (check for 24 VDC at harness during trial for ignition before replacing valve)
E 04	Power failure occurred after lockout	<ul style="list-style-type: none"> Some other error on this list occurred and power to the boiler was then interrupted. Reset control and see if hard lockout reoccurs.
E 05 E 06 E 07 E 11	Internal control failure	<ul style="list-style-type: none"> Reset the control. If problem reoccurs, replace the MCBA.
E 12	Low water cut-off circuit open	<ul style="list-style-type: none"> If yellow light on LWCO is on, system is low on water If neither yellow nor green light is on, check LWCO harness and check for 24VAC across AT140 transformer
E 13 E 14 E 15 E 16 E 17	Internal control failure	<ul style="list-style-type: none"> Reset the control. If problem reoccurs, replace the MCBA.
E 18	MCBA supply sensor detected temperatures in excess of 200°F for an extended period of time	<ul style="list-style-type: none"> See possible causes for “b18” error. Also, check safety limit for proper operation.
E 19	MCBA return sensor detected temperatures in excess of 200°F for an extended period of time	<ul style="list-style-type: none"> See possible causes for “b19” error.
E 28	Blower is not running when it should or fan speed signal not being detected by MCBA	<ul style="list-style-type: none"> Loose connection in 120 VAC fan wiring Loose or miswired fan speed harness Defective fan
E 29	Blower fan speed has not returned to zero rpm	<ul style="list-style-type: none"> Miswired fan speed harness Defective fan
E 31	Shorted supply temperature sensor	<ul style="list-style-type: none"> Shorted or miswired supply sensor wiring Defective supply sensor
E 32	Shorted return temperature sensor	<ul style="list-style-type: none"> Shorted or miswired return sensor wiring Defective return sensor
E 35	Flue gas temperature sensor short circuit	<ul style="list-style-type: none"> Shorted or miswired flue temp sensor wiring Defective flue temp sensor
E 36	Supply water temperature sensor circuit open	<ul style="list-style-type: none"> Loose or miswired supply sensor wiring Defective supply sensor
E 37	Return water temperature sensor circuit open	<ul style="list-style-type: none"> Loose or miswired return sensor wiring Defective return sensor
E 40	Flue gas temperature sensor circuit open	<ul style="list-style-type: none"> Loose or miswired flue temp sensor wiring Defective flue temp sensor
E 44	Internal control failure	<ul style="list-style-type: none"> Reset the control. If problem reoccurs, replace the MCBA.
E 52	Flue gas temperature over 230°F	<ul style="list-style-type: none"> Heat exchanger needs to be cleaned Boiler over-fired Air-fuel mixture out of adjustment - consult factory
E 60	Internal control failure	<ul style="list-style-type: none"> Reset the control. If problem reoccurs, replace the MCBA.

PAGE
INTENTIONALLY
LEFT
BLANK

XIV Parts

The following parts may be obtained from any Crown distributor. To find the closest Crown distributor, consult the area Crown representative or the factory at:

Crown Boiler Co.
Customer Service
P.O. Box 14818
Philadelphia, PA 19134
www.crownboiler.com

BWC REPLACEMENT PARTS LIST					
KEY	DESCRIPTION	BWC150		BWC225	
		CROWN PART #	QUANTITY	CROWN PART #	QUANTITY
1	Crown Aluminum Nameplate	98-004	1	98-004	1
2	Aluminum Door Knob	90-210	2	90-210	2
3	#8-32 x 1/4" H.W.H. Screw	90-211	2	90-211	2
4	Front Door Panel	240313	1	240310	1
5	#6-32 Hex Nylon Insert LockNut	900705	4	900705	4
6	Control Chassis Assembly	241203	1	241203	1
7	.125" ID x .250"OD Silicone Tubing	14-008	1.25'	14-008	1.25'
8	.125" ID x .250"OD Silicone Tubing	14-008	5.0'	14-008	5.1'
9	Vestibule Door Seal - Horizontal	240402	4	240401	4
10	Vestibule Door Seal - Vertical	240400	2	240400	2
11	#10 x 3/4 Hex Wsh Hd Screw	90-054	22	90-054	22
12	Lower Vestibule Door	240463	1	240460	1
13	U Type Speed Nut	90-217	22	90-217	22
14	Vinyl Grommet - .25" ID (For .875" Hole)	240900	1	240900	1
15	Miniature Hose Fitting 1/8" Barbed to 10-32 Male Thread	90-222	2	90-222	2
16	10-32 SS Hex Nut	90-219	1	90-219	1
17	#6-32 x 1/4" Hex x 1/2" Long Female-Female Steel Standoff	900710	4	900710	4
18	#6 -32 x 1 " H.W.H. Screw	900712	4	900712	4
19	Center Vestibule Door	240443	1	240440	1
20	#10 x 1/2 Hex Wsh Hd Screw	90-212	25	90-212	26
21	#10 Flat Washer	90-057	4	90-057	4
22	Inspection Port Window	980035	1	980035	1
23	Upper Vestibule Door	240453	1	240450	1
24	Partition	240403	1	240404	1
25	#10 x 1/2 Truss Hd Screw	900120	21	900120	21
26	Shutter Bushing for .875" Hole	96-050	2	96-050	2
27	Flat Wire Clip (Ribbon Cable)	900012	2	900012	2
28	Right Side Panel Assembly	240300	1	240300	1
29	5/16 ID Cable Clamp	96-052	1	96-052	1
30	Left Side Panel Assembly	240301	1	240301	1
31	3/4" Boiler Drain Valve	95-041	1	95-041	1
32	1-1/4" x 3/4" x 1-1/4" Bk Reducing Tee	95-045	1	95-045	1
33	Vinyl Grommet - .1.625" ID (For 2.625" Hole)	240903	2	240903	2
34	M6 x 1.0 x 12 Hex Hd Cap Screw	900004	2	900004	2
35	Trap Tubing (Condensate Drain)	240008	3.5'	240008	3.5'
36	3/8-16 x 5/8 Hex Hd Cap Screw	900430	4	900430	4
37	3/8 Flat Washer	90-036	4	90-036	4
38	1-1/4" x 6" Bk Nipple	95-0346	1	95-0346	1
39	1-1/4" x 19" Bk Nipple	950240	1	950240	1
40	2" ID x 2.25" OD Polypro/Rubber Duct Hose*	900750	19-1/2"	900750	14-3/4"
41	SAE # 32 Hose Clamp*	900730	1	900730	1
43	#10-24 x 3/8" Hex Wshr Hd Type F	NA	NA	900715	1
44	Aluminum Cable Tie Mount	960017	7	960017	9
45	Vinyl Grommet - .825" ID (For 1.625" Hole)	240902	1	240902	1
46	1/4-20 x 1/2 Self Tapping Screw	900100	4	900100	4

* Not used with Dungs gas train

BWC REPLACEMENT PARTS LIST					
KEY	DESCRIPTION	BWC150		BWC225	
		CROWN PART #	QUANTITY	CROWN PART #	QUANTITY
47	Nylon Glide Foot 1"Dia x 3/4" Long	700111	4	700111	4
48	Combination Base / Rear Panel	240303	1	240304	1
49	Vesibule Top Panel Assembly	240423	1	240420	1
50	Vent Seal Gasket	240503	1	240500	1
51	Vent Adapter Assembly	240504	1	240501	1
52	8-32 Hex Nylon Insert Locknut	900706	4	900706	4
53	Display Board	3501600	1	3501600	1
54	Nylon Spacer .25"L x .313"OD x .166"ID	960054	4	960054	4
55	Graphics Overlay Mounting Plate	240390	1	240390	1
56	Graphic Overlay Membrane For Display	980030	1	980030	1
57	Top Panel	240323	1	240320	1
58	Shorty Bushing for .875" Hole	960053	1	960053	1
59	Hydro Level Model 1100 Probe LWCO	450600	1	450600	1
60	1-1/4" Supply Fitting	950001	1	950001	1
61	3/4" x 2" Bk Nipple	950062	1	950062	1
62	3/4" x 1/4" Reducing Bushing	950017	1	950017	1
63	3/4" x 3/4" 30 psi Relief Valve	95-040	1	95-040	1
64	Tridicator Gauge	95-069	1	95-069	1
65	#6 -32 x 1/2" H.W.H. Screw Type F Screw	900713	8	900713	8
66	#4-40 x 1/2" Slotted H.W.H. Type F Screw	900470	8	900470	8
67	#10-32 x 3/16" Ground Screw	146-95-301	1	146-95-301	1
68	Control Chassis	240330	1	240330	1
69	4 X 4 J-Box	96-055	1	96-055	1
70	4 X 4 J-Box Cover Plate	96-054	1	96-054	1
71	Resistor Clamp .312" Dia	960090	1	960090	1
72	Terminal Block .375" c/c, 9-Pole	960095	1	960095	1
73	Pressure Switch	230009	1	240050	1
74	40VA Transformer (LWCO Power Supply)	35-2000	1	35-2000	1
75	Boiler Control Module	3524150U	1	3524225U	1
76	50VA Transformer (Boiler Control Module)	3502600	1	3502600	1
77a	M5 x 0.8 x 25mm, Set Screw	900002	4	900002	4
77b1	M5 x 0.8 x 30mm, Set Screw	NA	NA	9000025	1
77b2	M5 x 0.8 x 20mm, Set Screw	9000021	1	NA	NA
77c1	M5 x 0.8 x 20mm, Socket Hd Cap Screw	NA	NA	9000023	1
77c2	M5 x 0.8 x 12mm, Socket Hd Cap Screw	9000027	1	NA	NA
78	M5 x 0.8, Nylock Hex Nut	900003	5	900003	5
79 thru 82	Inlet Gas Elbow Flange Adapter w/ 4 mtg screws & o-ring	3501056	1	3501056	1
83	Combustion Air Blower (Honeywell Valve)	240002	1	240000	1
84	Venturi Gasket	3501075	2	3501075	2
85	Aluminum Pressure Tap Block	240100	1	240100	1
86	VK8115 Gas Control w/ 45.900.446- Venturi Manifold	3507335	1	3507330	1
87	Combustion Blower Flange Gasket	240001	1	240001	1
88	1/2" Gas Cock (supplied loose)	950615	1		
88	3/4" Gas Cock (supplied loose)			950600	1

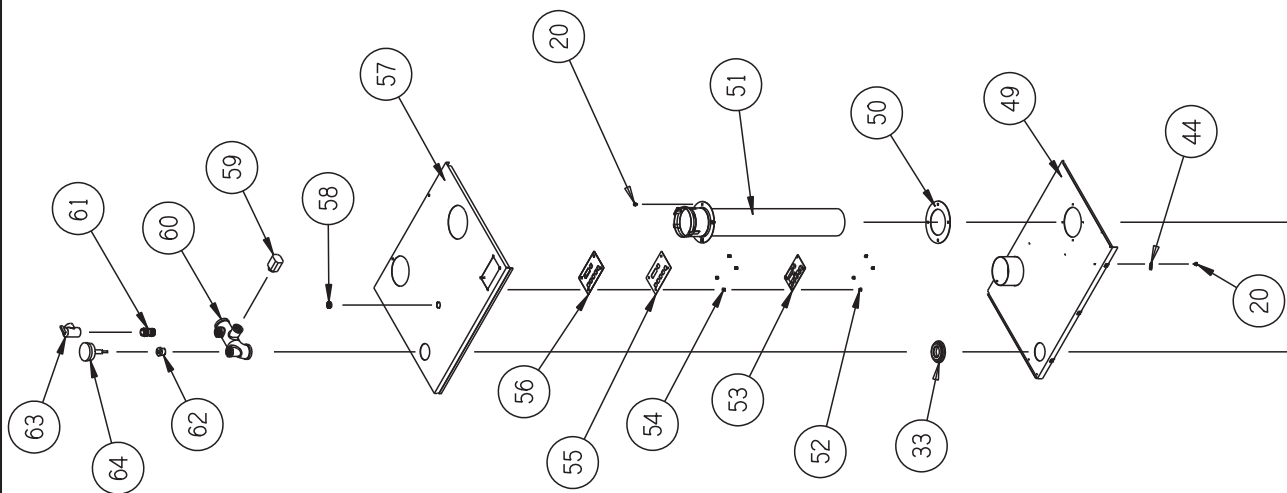

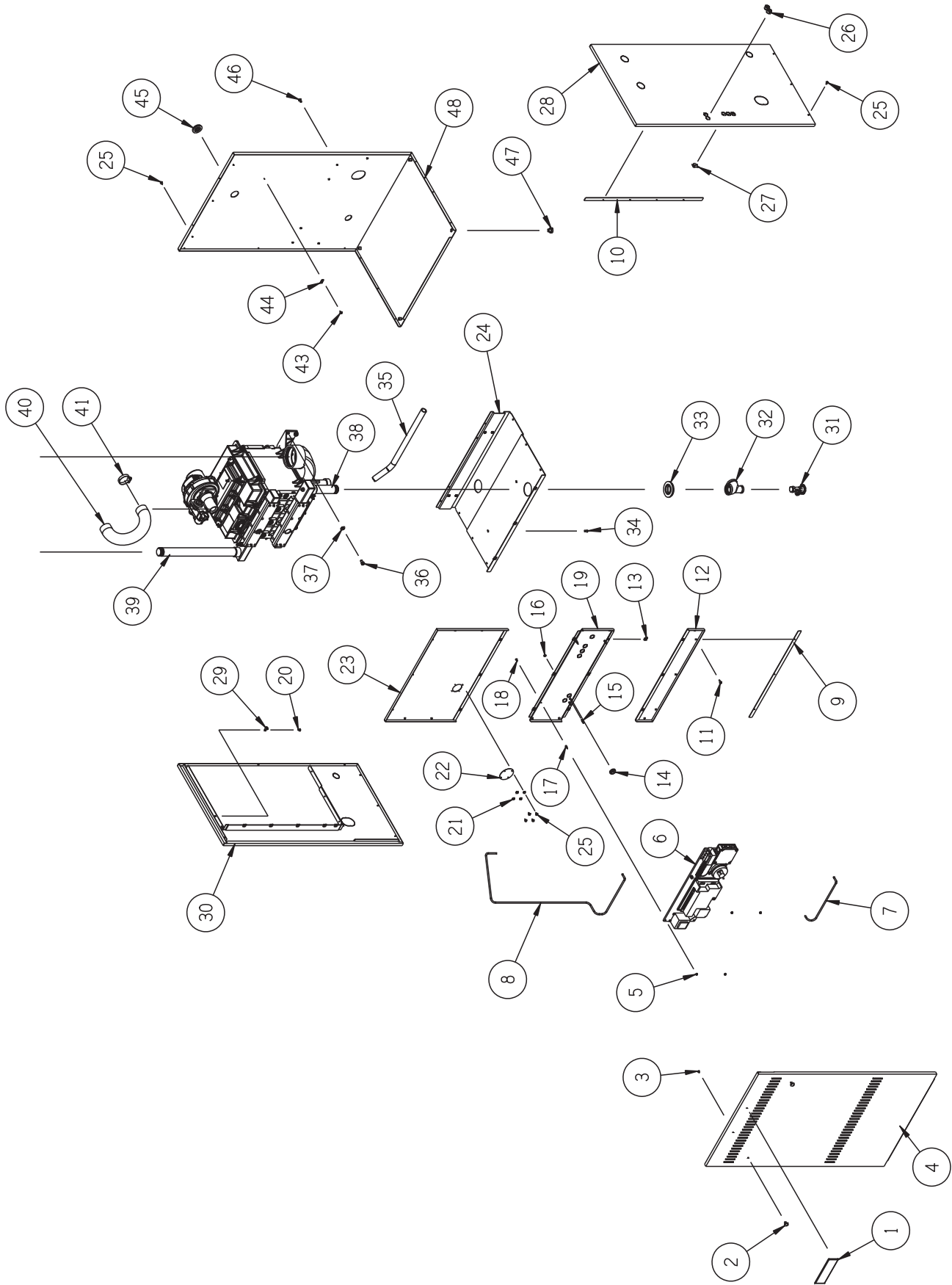

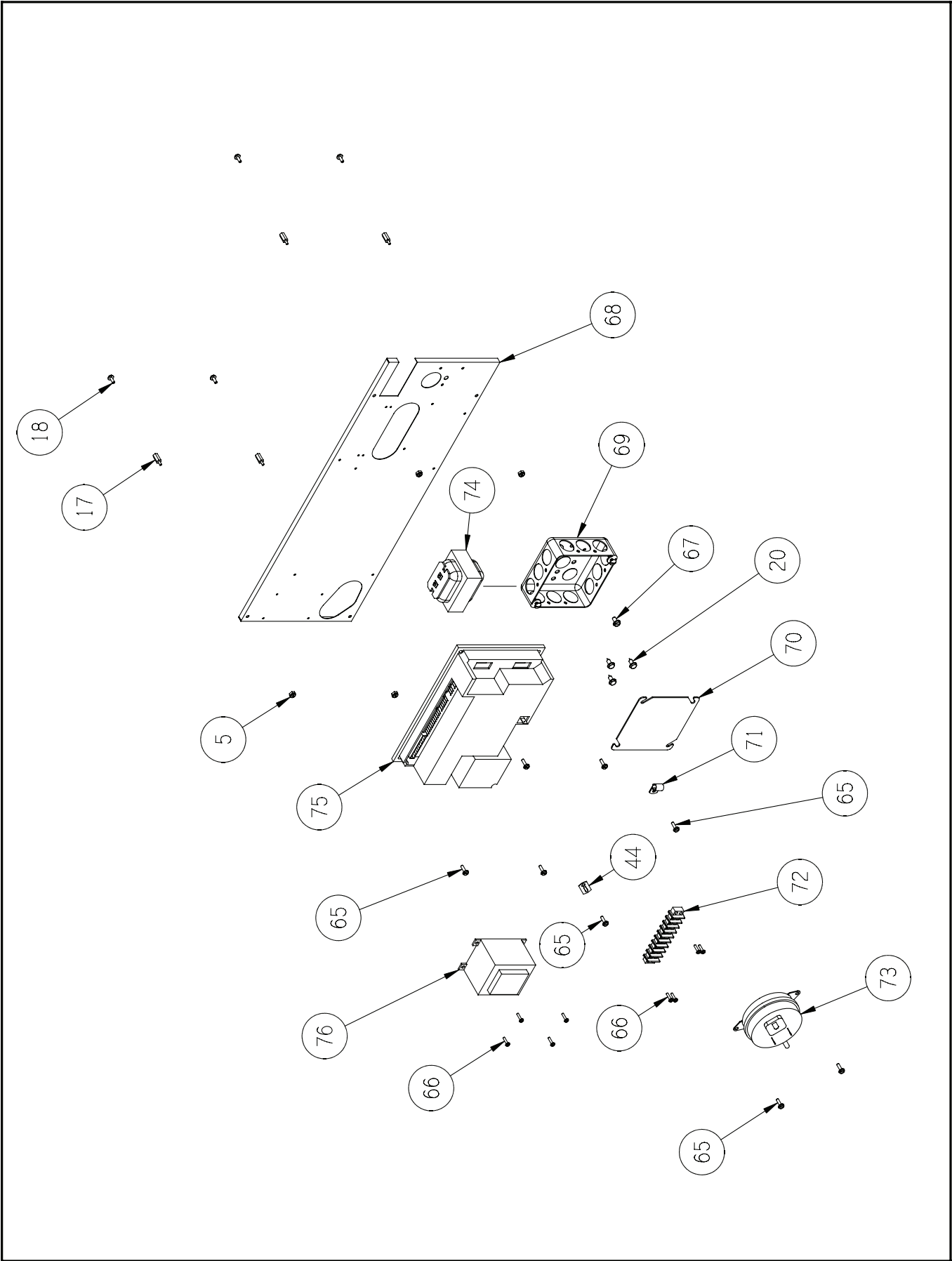

Gas Train Assembly (Honeywell Valve)

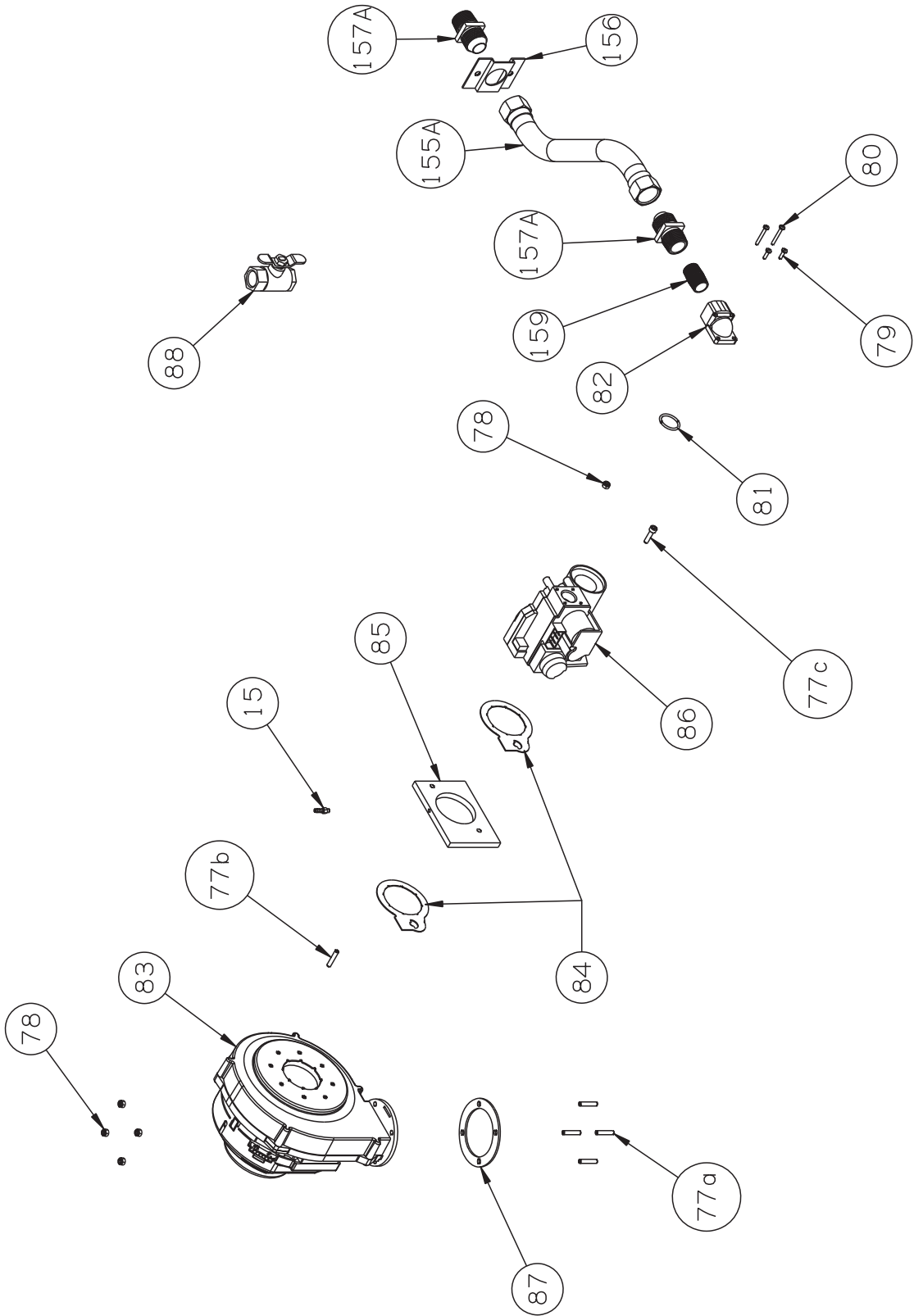

Gas Train Assembly (Dungs Valve)

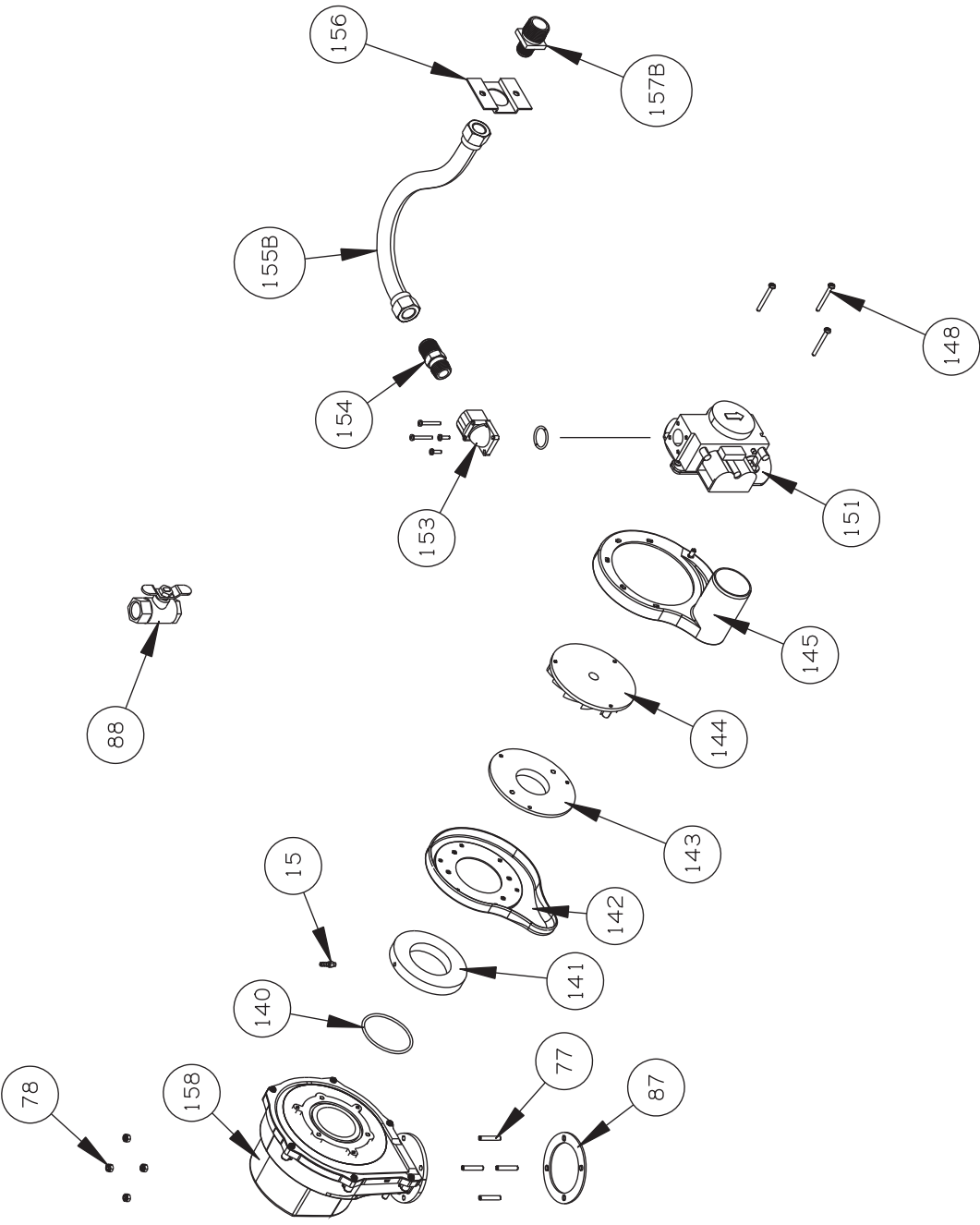

BWC REPLACEMENT PARTS LIST					
KEY	DESCRIPTION	BWC150		BWC225	
		CROWN PART #	QUANTITY	CROWN PART #	QUANTITY
89	#6-32 x 13mm Hex x 92mm, Long Standoff	900711	2	900711	2
90	M6 x 1.0 x 75mm, Hex Head Screw	240960	16	240960	16
91	Manifold Seal Ring, EPDM	240200	8	240200	8
92	M6 x 1.0 x 30mm, SS Hex Socket Set Screw	240961	6	240961	6
93	M6 x 1.0, Lock Washer	240962	6	240962	6
94	M4 x 0.7 x 12mm, Phillips Pan Head Mach. Screw	240925	2	240925	2
95A	M4 x 0.7 x 20mm, SS Hex Socket Set Screw	240920	2	240920	2
95B	M4 x 0.7, Hex Nut, NP	240921	2	240921	2
96	M6 x 1.0 x 35mm, SS Hex Socket Set Screw	240965	8	240965	8
97	M6 x 1.0, Captive Washer Hex Nut	240905	8	240905	8
98	4.2 x 9.5mm, Pan Head Screw	240915	6	240915	6
99A	Condensate Trap Less Connecting Pipe	240955	1	240955	1
99B	Connecting Pipe For Condensate Trap	240956	1	240956	1
100	Water Manifold Mounting Plate	240233	2	240234	2
101	Return Manifold	240243	1	240244	1
102	Supply Manifold	240253	1	240254	1
103	Inspection Cover Plate	240263	1	240264	1
104	Inspection Cover Gasket, EDPM	240273	1	240274	1
105	Sight Glass Holder	240951	1	240951	1
106	Sight Glass	240950	1	240950	1
107	Sight Glass Gasket, 5mm	240952	2	240952	2
109	Ignition Electrode	240010	1	240007	1
110	Ignition Electrode Gasket, 5mm	240011	1	240011	1
111	Exhaust Pipe Lip Ring Seal	240039	1	240049	1
112	Burner Hood	240030	1	240040	1
113	Burner	240036	1	240045	1
114	Burner Hood Seal	240032	1	240042	1
115	Burner Air Distributor Plate	240038	1	240048	1
116	Nipple, Pressure Measuring, G1/8"	240910	1	240910	1
117	Hi Temperature Limit Switch	960124	1	960124	1
118	Sensor	240012	3	240012	3
119	M6 x 1.0, Nylock Hex Nut	240968	6	240968	6
120	Condensate Trap Gasket	240005	1	240005	1
121	X1 Outer Vestibule Line Voltage Harness	9602404	1	9602404	1
122	X2 Outer Vestibule Control Harness	9602408	1	9602408	1
123	X3/X4 Outer Vestibule Sensor Harness	9602406	1	9602406	1
124	Line Voltage Blower Harness / Ignition Ground Wire (j-box)	9602415	1	9602415	1
125	Gas Valve Harness (Honeywell Valve)	9602403	1	9602403	1
125	Gas Valve Harness (Dungs Valve)	9602305	1	TBD	1
126	Inner Vestibule Blower Control Harness	9602402	1	9602402	1
127	Inner Vestibule Hi Limit Harness	9602410	1	9602410	1
128	Inner Vestibule Sensor Harness	9602405	1	9602405	1
129	Inner Vestibule Line Voltage Blower Harness	9602401	1	9602401	1
130	Ignition (Spark) Cable Harness	9602413	1	9602413	1
131	Ribbon Cable Display Harness	9602400	1	9602400	1
132	Vented Dust Cap	240990	1	240990	1

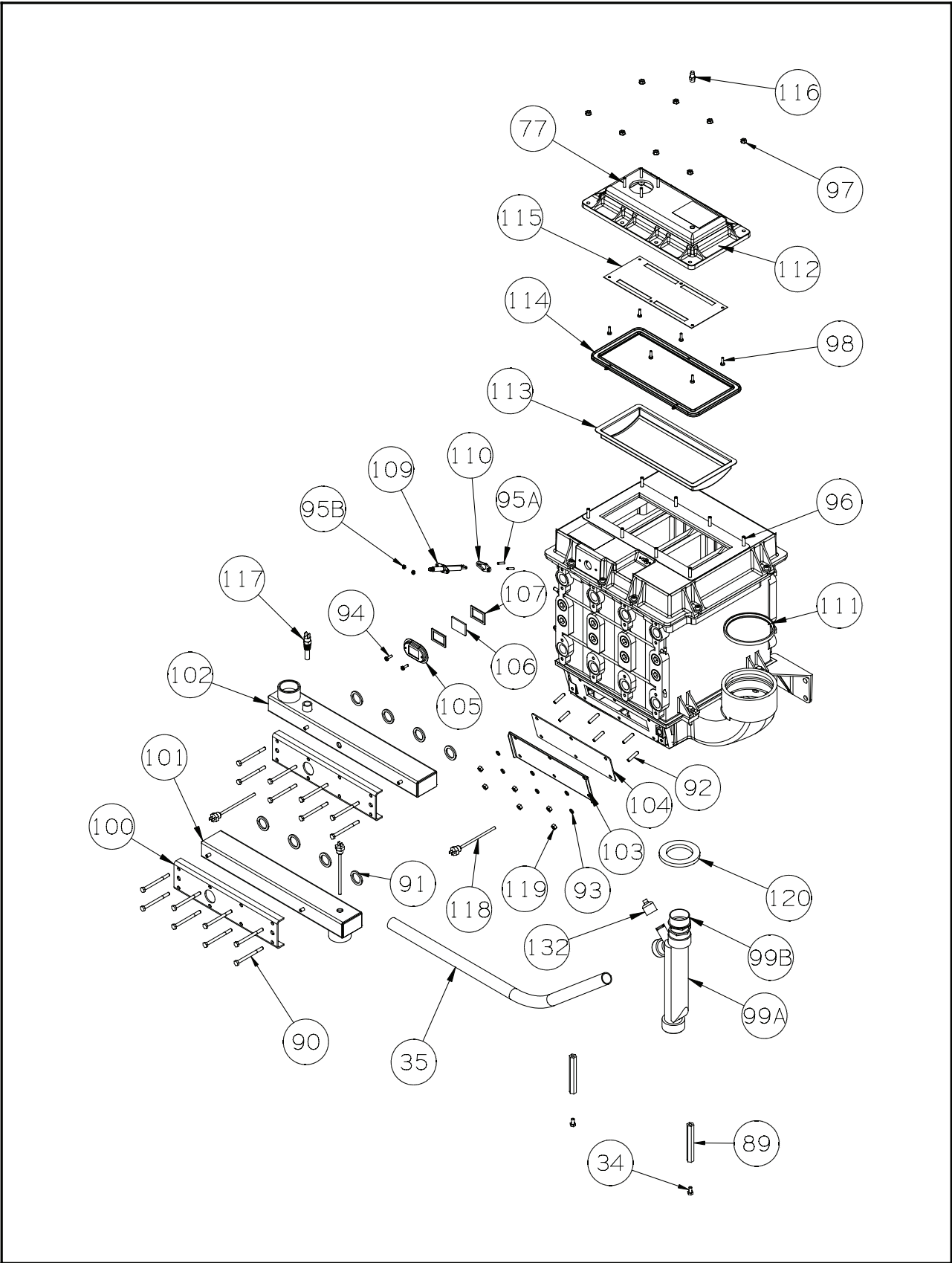

BWC REPLACEMENT PARTS LIST					
KEY	DESCRIPTION	BWC150		BWC225	
		CROWN PART #	QUANTITY	CROWN PART #	QUANTITY
140	3 x 63mm O-Ring	230003	1	NA	1
141	Fan Inlet Block	230150	1	NA	1
142	Dungs Air Inlet Adapter (Male)	3507345	1	NA	1
143	42.5 Short Fan Adaptor Plate	3507346	1	NA	1
144	12mm (Gray) Swirlplate	3507336	1	NA	1
145	Dungs Air Inlet Adaptor (Female)	3507344	1	NA	1
148	M4 x 45mm Screws	3507343	3	NA	3
151	Dungs Gas Valve Assembly	3507325	1	NA	1
153	Inlet Gas Elbow Flange Adapter w/ 4 mtg screws & O-ring	3507326	1	NA	1
154	5/8"OD x 1/2" MPT CSST Adaptor	230715	1	NA	1
155A	3/4" x 20" Yellow Coated CSST			230725	1
155B	1/2" x 13" Yellow Coated CSST	230707	1		
156	Bulkhead Bracket	230721	1	230721	1
157A	3/4" Bulkhead CSST Adapter			230724	2
157B	5/8" Bulkhead CSST Adaptor	230720	1		
158	Combustion Air Blower (Dungs Valve)	230002	1	NA	1
159	1/2" Close Nipple			95-021	1
Not Shown	3/4" Bulkhead CSST Adaptor	NA	-	230724	2
Not Shown	3/4" x 20" Yellow Coated CSST	NA	-	230725	1
Not Shown	11-1/2" Releasable Nylon Cable Wire Tie	960025	1	960025	1
Not Shown	6" Nylon Wire Tie	97-090	10	97-090	11
Not Shown	1-5/8" Hole Plug	900735	1	900735	1
Not Shown	5mm x 20mm Fast Acting, Ceramic Tube, 5 Amp Fuse	960005	1	960005	1
Not Shown	5mm x 20mm Time Delay, Glass Tube, 4 Amp Fuse	960004	1	960004	1
Not Shown	1/2" NPT x 3-1/2" Nipple	950063	1	NA	NA
Not Shown	1/2" NPT 90° Elbow	950049	1	NA	NA
Not Shown	Violet Jumper Wire	9602412	1	9602412	1

WIRE CODE
 BK - BLACK
 BL - BLUE
 BR - BROWN
 GR - GREY
 PI - PINK
 RD - RED
 V - VIOLET
 WH - WHITE
 YE - YELLOW

WIRE TYPE LEGEND

- LOW VOLTAGE SIZE 18 AWG TYPE TEWAWM STRANDED WIRE - 105°C
- LINE VOLTAGE SIZE 14 AWG TYPE TW OR TEWAWM WIRE
- LINE VOLTAGE SIZE 18 AWG TYPE TW OR TEWAWM WIRE
- IGNITOR - 250°C
- GROUND - SIZE 18 AWG TYPE SF-2, STRANDED WIRE, 122' INSULATION - 200°C

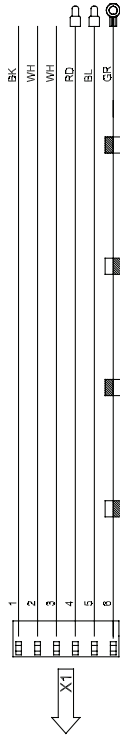

X1 Outer Vestibule Line Voltage Harness

121

123

X3/X4 Outer Vestibule Sensor Harness

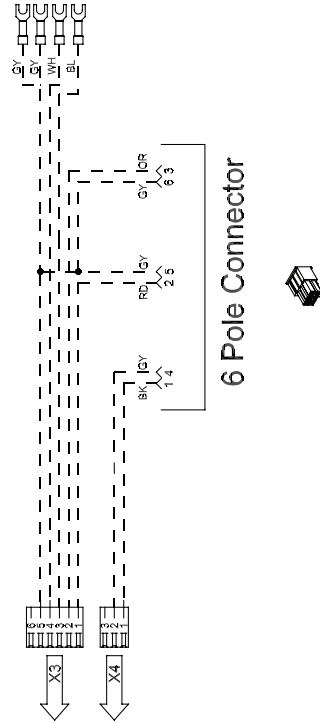

6 Pole Connector

122

124

X2 Outer Vestibule Control Harness

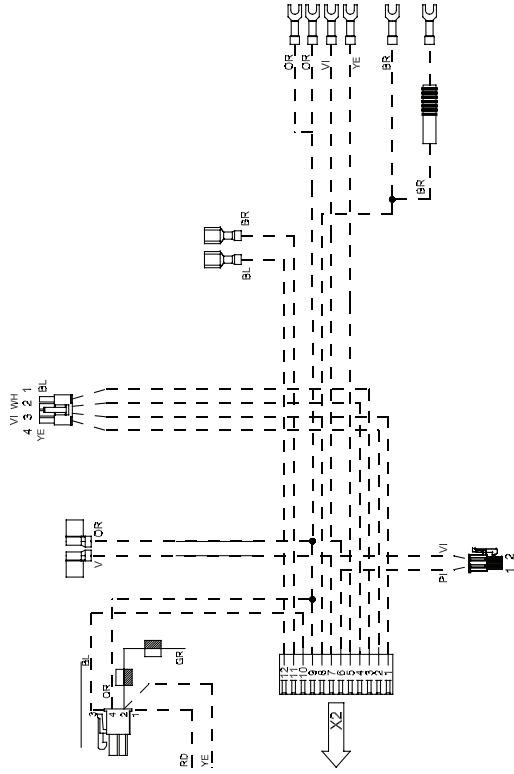

Line Voltage Blower Harness / Ignition (Spark) Ground Wire Assembly (j-box)

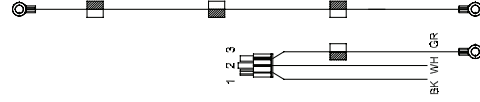

WIRE CODE

- BK - BLACK
- BL - BLUE
- BR - BROWN
- GR - GREEN
- GY - GREY
- OR - ORANGE
- PI - PINK
- RD - RED
- VT - VIOLET
- WH - WHITE
- YE - YELLOW

WIRE TYPE LEGEND

- LOW VOLTAGE SIZE 18 AWG TYPE TEWAWM STRANDED WIRE - 105°C
- LINE VOLTAGE SIZE 14 AWG TYPE TW OR TEWAWM WIRE
- LINE VOLTAGE SIZE 18 AWG TYPE TW OR TEWAWM WIRE
- LINE VOLTAGE SIZE 18 AWG TYPE SF-2 STRANDED WIRE - 105°C
- GROUND - SIZE 18 AWG TYPE SF-2, STRANDED WIRE, 1/32" INSULATION - 200°C

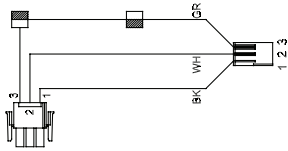

Inner Vestibule Line Voltage Blower Harness

129

130

131

Ribbon Cable Display Harness

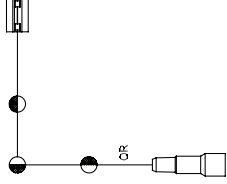
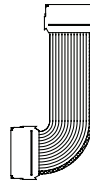

Ignition (Spark) Cable Harness

Appendix A: Special Requirements For Side-Wall Vented Appliances In The Commonwealth of Massachusetts

IMPORTANT

The Commonwealth of Massachusetts requires compliance with regulation 248 CMR 4.00 and 5.00 for installation of side-wall vented gas appliances as follows:

1. For direct-vent appliances, mechanical-vent heating appliances or domestic hot water equipment, where the bottom of the vent terminal and the air intake is installed below four feet above grade the following requirements must be satisfied:
 - a. If there is not already one present, on each floor level where there are bedroom(s), a carbon monoxide detector and alarm shall be placed in the living area outside the bedroom(s). The carbon monoxide detector shall comply with NFPA 720 (2005 Edition).
 - b. A carbon monoxide detector shall be located in the room that houses the appliance or equipment and shall:
 - i. Be powered by the same electrical circuit as the appliance or equipment such that only one service switch services both the appliance and the carbon monoxide detector;
 - ii. Have battery back-up power;
 - iii. Meet ANSI/UL 2034 Standards and comply with NFPA 720 (2005 Edition); and
 - iv. Have been approved and listed by a Nationally Recognized Testing Laboratory as recognized under 527 CMR.
 - c. A product-approved vent terminal must be used, and if applicable, a product-approved air intake must be used. Installation shall be in strict compliance with the manufacturer's instructions. A copy of the installation instructions shall remain with the appliance or equipment at the completion of the installation.
 - d. A metal or plastic identification plate shall be mounted at the exterior of the building, four feet directly above the location of the vent terminal. The plate shall be of sufficient size to be easily read from a distance of eight feet away, and read "Gas Vent Directly Below".
2. For direct-vent appliances, mechanical-vent heating appliances or domestic hot water equipment, where the bottom of the vent terminal and the air intake is installed above four feet above grade the following requirements must be satisfied:
 - a. If there is not already one present, on each floor level where there are bedroom(s), a carbon monoxide detector and alarm shall be placed in the living area outside the bedroom(s). The carbon monoxide detector shall comply with NFPA 720 (2005 Edition).
 - b. A carbon monoxide detector shall :
 - i. Be located in the room that houses the appliance or equipment
 - ii. Be either hard-wired or battery powered or both; and
 - iii. Comply with NFPA 720 (2005 Edition)
 - c. A product-approved vent terminal must be used, and if applicable, a product-approved air intake must be used. Installation shall be in strict compliance with the manufacturer's instructions. A copy of the installation instructions shall remain with the appliance or equipment at the completion of the installation.



Manufacturer of Hydronic Heating Products
P.O. Box 14818 3633 I. Street
Philadelphia, PA 19134
www.crownboiler.com